

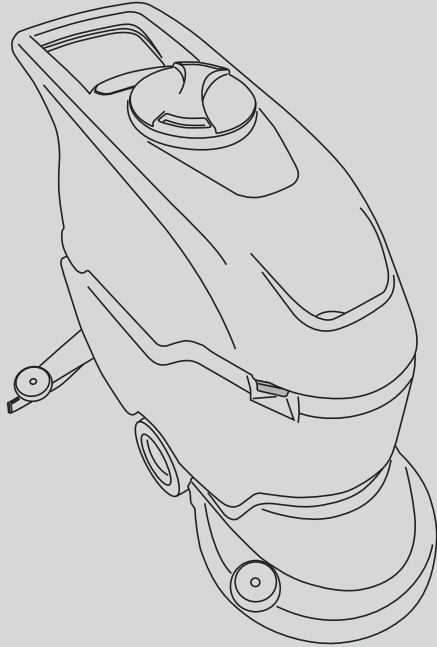

# T290 T390

## BATTERY FLOOR SCRUBBER

OPERATOR'S MANUAL (EN)



**Model Part No.:**

LPTB03303 - SCRUBBER [T290 50CM PAD ASSIST, PD,ANZ]

LPTB03304 - SCRUBBER [T290 50CM,PD,ANZ]

LPTB03305 - SCRUBBER [T390 70CM,PD,ANZ]



**ANZ**



To view, print or download  
the parts manual, visit:  
[www.tennantco.com/manuals](http://www.tennantco.com/manuals)

TECHNICAL SPECIFICATIONS  
 CARACTERISTIQUES TECHNIQUES  
 CARACTERÍSTICAS TÉCNICAS  
 CARACTERÍSTICAS TÉCNICAS

## T290

Cleaned track width Largeur de nettoyage Ancho de trabajo Largura de limpeza	mm	510
	inch	20
Squeegee width Largeur suceur Ancho secador Largura do squeegee	mm	816
	inch	32
Hourly performance Rendement horaire Rendimiento horario Rendimento horário	m <sup>2</sup> /h	<b>B:</b> 1750 <b>BT:</b> 1820
	ft <sup>2</sup> /h	<b>B:</b> 18837 <b>BT:</b> 19600
Number of brushes Nombre de brosses Número de cepillos Número de escovas	n°	1
Cleaning tool diameter Diamètre de l'outil de nettoyage Diámetro de la herramienta de limpieza Diâmetro da ferramenta de limpeza	mm	510
	inch	20
Max brush pressure Pression brosses max Presión máx. del cepillo Pressão máx. das escovas	gr/cm <sup>2</sup> kPa	11,54 0,98
	Kg lbs	18,40 40
Brush rotation speed Vitesse de rotation de la brosse Velocidad de rotación del cepillo Velocidade de rotação da escova	g/1 <sup>1</sup> RPM	155
Brush motor power Puissance moteur de la brosse Potencia motor del cepillo Potência do motor da escova	W	550
	HP	0,73
Drive control Traction Tracción Tração	/	<b>B:</b> Mechanical <b>BT:</b> Electronic
Drive motor rated power Puissance nominale du moteur de traction Potencia nominal motor de tracción Potência nominal do motor de tração	W	<b>B:</b> / <b>BT:</b> 120
	HP	<b>B:</b> / <b>BT:</b> 0,16
Maximum speed Vitesse maxi Velocidad máxima Velocidade máxima	Km/h	<b>B:</b> 3 <b>BT:</b> 3,5
	mph	<b>B:</b> 1,8 <b>BT:</b> 2,17
Suction motor power Puissance du moteur d'aspiration Potencia motor de aspiración Potência do motor de aspiração	W	480
	HP	0,65
Solution tank Réservoir de solution Depósito de detergente Depósito da solução	L	40
	gal	10,5
Dirty water tank Réservoir de récupération Depósito de agua sucia Depósito de recolha	l	45
	gal	11,8

Wheel diameter Diamètre des roues Diámetro de ruedas Diâmetro das rodas	mm	200
	inch	7,87
Gross weight Poids brut Peso Bruto Peso bruto	Kg	202
	lbs	445
Transported weight Poids transporté Peso Transportado Peso transportado	Kg	<b>B: 139</b> <b>BT: 145</b>
	lbs	<b>B: 306.44</b> <b>BT: 319.67</b>
Number of batteries Nombre de batteries Número de baterías Número de baterias	n°	2
Battery voltage in series Tension des batteries en série Tensión de baterías en serie Tensão das baterias em série	V	24
Single battery capacity Capacité de chaque batterie Capacidad de cada batería Capacidade de cada bateria	Ah(20)	130 - 140 -150
Single battery weight Poids de chaque batterie Peso de cada batería Peso de cada bateria	Kg	36
	lbs	79,3
Power cable length Longueur du câble d'alimentation Largo cable de alimentación Comprimento do cabo de alimentação	mm	/
Power supply voltage Tension d'alimentation Tensión de alimentación Tensão de alimentação	V	/
Power supply frequency Fréquence d'alimentation Frecuencia de alimentación Frequência de alimentação	Hz	/
Battery compartment dimensions (length, width, height) Dimensions du coffet des batteries (longueur, largeur, hauteur) Dimensiones del compartimiento de baterías (largo, ancho, alto) Dimensão do compartimento das baterias (comprimento, largura, altura)	mm	345x 170x 300
	inch	13,5x 6,7x 11,8
Machine dimensions (length, width, height) Dimensions de la machine (longueur, largeur, hauteur) Dimensiones de la máquina (largo, ancho, alto) Dimensões da máquina (comprimento, largura, altura)	mm <b>X/Y/Z</b>	1230x 520x 960
	inch <b>X/Y/Z</b>	48,42x 20,47x 37,8
Dimensions of packaging (length, width, height) Dimensions de l'emballage (longueur, largeur, hauteur) Dimensiones del embalaje (largo, ancho, alto) Dimensões da embalagem (comprimento, largura, altura)	mm	1270x 680x 1227
	inch	50x 26,7x 48,3
Sound pressure Pression sonore Presión Acústica Pressão sonora	LpA [dB]	74
(measurement uncertainty) k (incertitude de mesure) k (incertidumbre de las medidas) k (incertezas da medida) k	K [dB]	3,2

Hand-arm vibration Vibrations mains Vibración transmitida a la mano Vibrações transmitidas ao sistema mão-braço	HAV [m/sec <sup>2</sup> ]	0,9
(measurement uncertainty) k (incertitude de mesure) k (incertidumbre de medidas) k (incertezas da medida) k	[m/sec <sup>2</sup> ]	0,5

**Tab. A**

Data may be changed without notice.

Les caractéristiques techniques sont susceptibles d'être modifiées sans préavis.

Los datos pueden variar sin aviso previo

Os dados poderão ser alterados sem aviso prévio.

MACHINE DIMENSIONS  
DIMENSIONS DE LA MACHINE  
DIMENSIONES DE LA MÁQUINA  
DIMENSÕES DA MÁQUINA

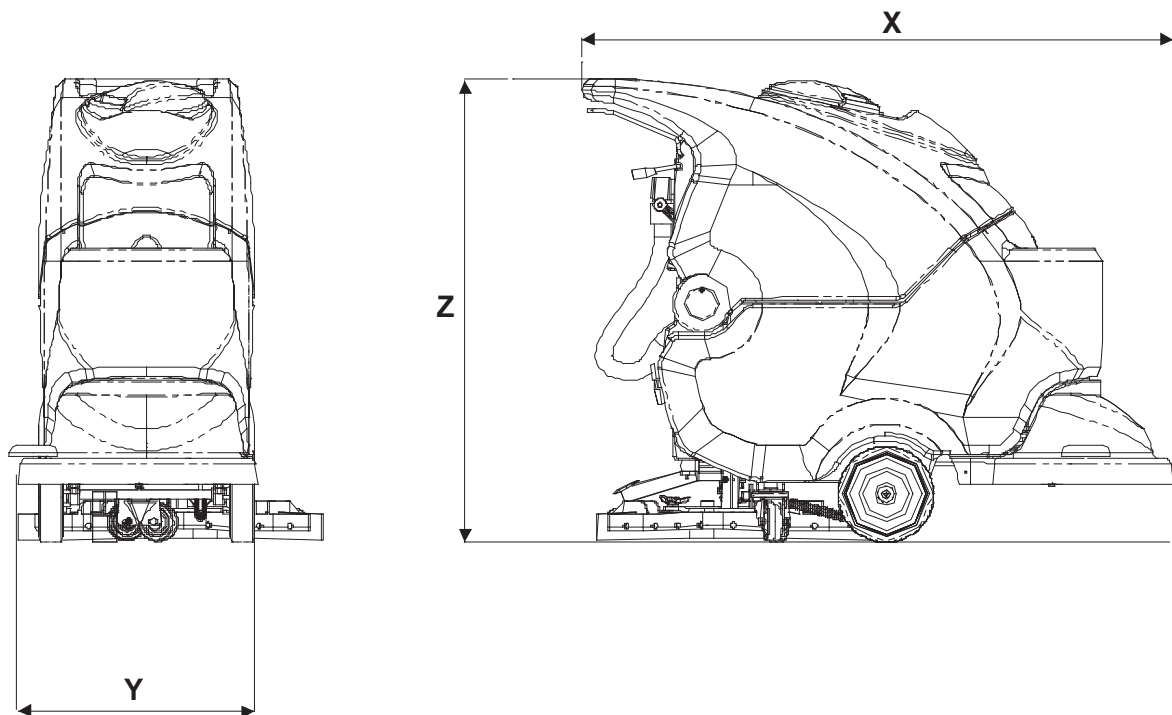

- X-Y-Z: See table "TECHNICAL SPECIFICATIONS"
- X-Y-Z: Voir tab. "DONNEES TECHNIQUES"
- X-Y-Z: Vease tab. "CARACTERÍSTICAS TÉCNICAS"
- X-Y-Z: Ver a tabela "CARACTERÍSTICAS TÉCNICAS"

**TECHNICAL SPECIFICATIONS**  
**CARACTERISTIQUES TECHNIQUES**  
**CARACTERÍSTICAS TÉCNICAS**  
**CARACTERÍSTICAS TÉCNICAS**

<b><u>T390</u></b>		
Cleaned track width Largeur de nettoyage Ancho de trabajo Largura de limpeza	mm	700
	inch	28
Squeegee width Largeur suceur Ancho secador Largura do squeegee	mm	942
	inch	37
Hourly performance Rendement horaire Rendimiento horario Rendimento horário	m <sup>2</sup> /h	2848
	ft <sup>2</sup> /h	30655
Number of brushes Nombre de brosses Número de cepillos Número de escovas	n°	2
Cleaning tool diameter Diamètre de l'outil de nettoyage Diámetro de la herramienta de limpieza Diâmetro da ferramenta de limpeza	mm	700
	inch	28
Max brush pressure Pression brosses max Presión máx. del cepillo Pressão máx. das escovas	gr/ cm <sup>2</sup>	23,58
	kPa	2,1
Brush rotation speed Vitesse de rotation de la brosse Velocidad de rotación del cepillo Velocidade de rotação da escova	g/1 <sup>1</sup> RPM	215
Brush motor power Puissance moteur de la brosse Potencia motor del cepillo Potência do motor da escova	W	300
	HP	0,4
Drive control Traction Tracción Tração	/	<b>BT: Electronic</b>
Drive motor rated power Puissance nominale du moteur de traction Potencia nominal motor de tracción Potência nominal do motor de tração	W	<b>B: /</b> <b>BT: 180</b>
	HP	<b>B: /</b> <b>BT: 0,24</b>
Maximum speed Vitesse maxi Velocidad máxima Velocidade máxima	Km/h	4,2
	mph	2,6
Suction motor power Puissance du moteur d'aspiration Potencia motor de aspiración Potência do motor de aspiração	W	480
	HP	0,64
Solution tank Réservoir de solution Depósito de detergente Depósito da solução	l	65
	gal	17
Dirty water tank Réservoir de récupération Depósito de agua sucia Depósito de recolha	l	70
	gal	18,5
Wheel diameter Diamètre des roues Diámetro de ruedas Diâmetro das rodas	mm	200
	inch	7,8

Gross weight Poids brut Peso Bruto Peso bruto	Kg	250
	lbs	551
Transported weight Poids transporté Peso Transportado Peso transportado	Kg	181
	lbs	399.04
Number of batteries Nombre de batteries Número de baterías Número de baterías	n°	2
Battery voltage in series Tension des batteries en série Tensión de baterías en serie Tensão das baterias em série	V	24
Single battery capacity Capacité de chaque batterie Capacidad de cada batería Capacidade de cada bateria	Ah (5h)	110
	Ah (20h)	140
Single battery weight Poids de chaque batterie Peso de cada batería Peso de cada bateria	Kg	36
	lbs	79,3
Power cable length Longueur du câble d'alimentation Largo cable de alimentación Comprimento do cabo de alimentação	mm	/
Power supply voltage Tension d'alimentation Tensión de alimentación Tensão de alimentação	V	/
Power supply frequency Fréquence d'alimentation Frecuencia de alimentación Frequência de alimentação	Hz	/
Battery compartment dimensions (length, width, height) Dimensions du coffet des batteries (longueur, largeur, hauteur) Dimensiones del compartimiento de baterías (largo, ancho, alto) Dimensão do compartimento das baterias (comprimento, largura, altura)	mm	345x 170x 300
	inch	13,5x 6,6 11,8
Machine dimensions (length, width, height) Dimensions de la machine (longueur, largeur, hauteur) Dimensiones de la máquina (largo, ancho, alto) Dimensões da máquina (comprimento, largura, altura)	mm <b>X/Y/Z</b>	1220x 748x 960
	inch <b>X/Y/Z</b>	48x 29x 37,7
Dimensions of packaging (length, width, height) Dimensions de l'emballage (longueur, largeur, hauteur) Dimensiones del embalaje (largo, ancho, alto) Dimensões da embalagem (comprimento, largura, altura)	mm	1245x 820x 1395
	inch	49x 32,2x 54,9
Sound pressure Pression sonore Presión Acústica Pressão sonora	LpA [dB]	73
(measurement uncertainty) k (incertitude de mesure) k (incertidumbre de las medidas) k (incertezas da medida) k	K [dB]	3,2
Hand-arm vibration Vibrations mains Vibración transmitida a la mano Vibrações transmitidas ao sistema mão-braço	HAV [m/ sec <sup>2</sup> ]	1

(measurement uncertainty) k (incertitude de mesure) k (incertidumbre de medidas) k (incertezas da medida) k	[m/ sec <sup>2</sup> ]	0,5
--	---------------------------	-----

**Tab. A**

Data may be changed without notice.

Les caractéristiques techniques sont susceptibles d'être modifiées sans préavis.

Los datos pueden variar sin aviso previo

Os dados poderão ser alterados sem aviso prévio.

MACHINE DIMENSIONS  
DIMENSIONS DE LA MACHINE  
DIMENSIONES DE LA MÁQUINA  
DIMENSÕES DA MÁQUINA

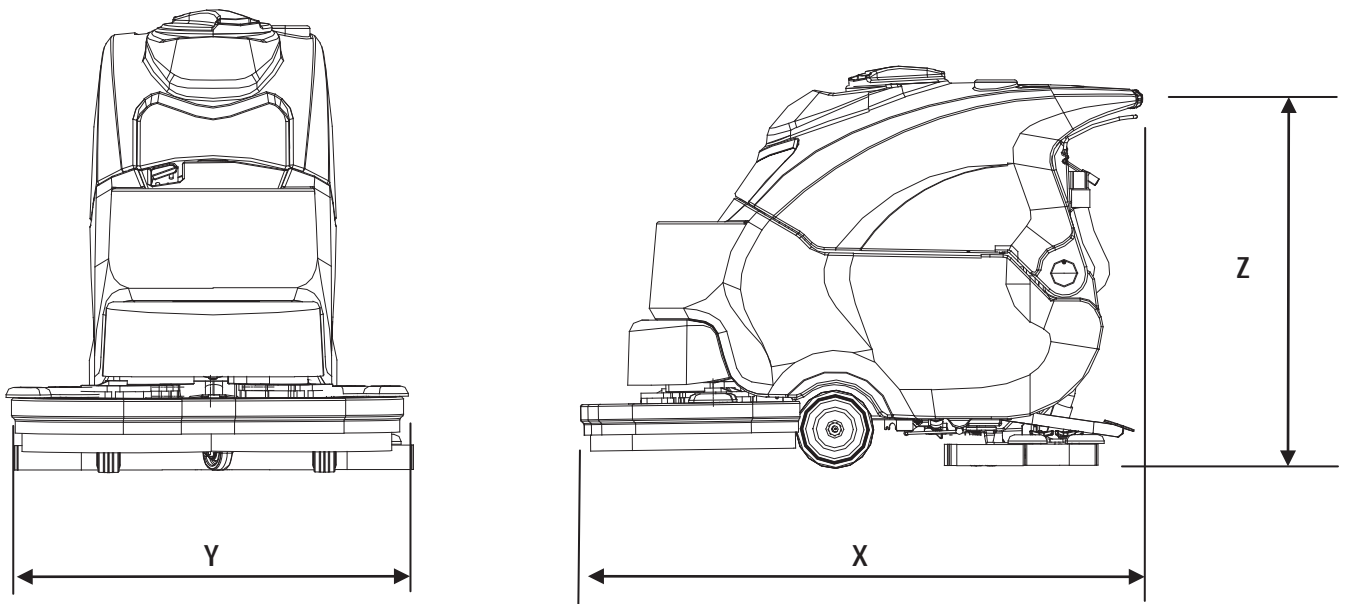

X-Y-Z: See table "TECHNICAL SPECIFICATIONS"  
X-Y-Z: Voir tab. "DONNEES TECHNIQUES"  
X-Y-Z: Vease tab. "CARACTERÍSTICAS TÉCNICAS"  
X-Y-Z: Ver a tabela "CARACTERÍSTICAS TÉCNICAS"

SAFETY SIGNS  
 PICTOGRAMMES DE SÉCURITÉ  
 SEÑALES DE SEGURIDAD  
 SINAIS DE SEGURANÇA



IMPORTANT, CUTTING HAZARD  
 ATTENTION, RISQUE DE COUPURE  
 ATENCIÓN, PELIGRO DE AMPUTACIÓN  
 ATENÇÃO, RISCO DE CORTE



IMPORTANT, CRUSHING HAZARD  
 ATTENTION, RISQUE D'ÉCRASEMENT DES MEMBRES  
 ATENCIÓN, APLASTAMIENTO DE LOS MIEMBROS  
 ATENÇÃO, RISCO DE ESMAGAMENTO DOS MEMBROS



IMPORTANT, ABRASION HAZARD  
 ATTENTION, RISQUE D'ABRASION  
 ATENCIÓN, PELIGRO DE ABRASIÓN  
 ATENÇÃO, RISCO DE ABRASÃO



DISPOSAL SYMBOL, CAREFULLY READ THE SECTION SHOWING THIS SYMBOL.  
 PICTOGRAMME DE COLLECTE SÉLECTIVE, LIRE ATTENTIVEMENT LA SECTION MARQUÉE DE CE PICTOGRAMME.  
 SÍMBOLO DE CONTENEDOR TACHADO, LEER DETENIDAMENTE LA SECCIÓN CON ESTE SÍMBOLO.  
 SÍMBOLO DE ELIMINAÇÃO, LER ATENTAMENTE A SECÇÃO COM ESTE SÍMBOLO



MAXIMUM SLOPE  
 PENTE FRANCHISSABLE  
 PENDIENTE SUPERABLE  
 INCLINAÇÃO SUPERÁVEL

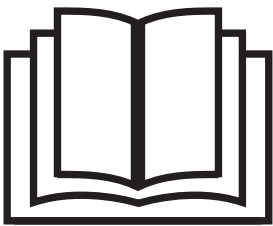

READ THE OPERATOR'S MANUAL  
 LIRE LE MANUEL DE L'OPÉRATEUR  
 LEER EL MANUAL DEL OPERADOR  
 LER O MANUAL DO OPERADOR

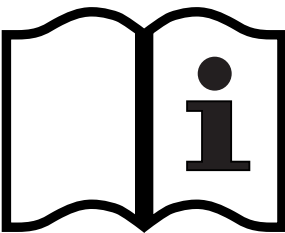

OPERATOR'S MANUAL, OPERATING INSTRUCTIONS  
 MANUEL DE L'OPÉRATEUR, INSTRUCTIONS POUR LE FONCTIONNEMENT  
 MANUAL DEL OPERADOR, INSTRUCCIONES DE FUNCIONAMIENTO  
 MANUAL DO OPERADOR, INSTRUÇÕES DE FUNCIONAMENTO



INSULATION CLASS, THIS CLASSIFICATION ONLY APPLIES TO BATTERY-POWERED MACHINES.  
CLASSE D'ISOLATION, CETTE CLASSIFICATION N'EST VALABLE QUE POUR LES MACHINES À BATTERIE.  
CLASE DE AISLAMIENTO III, ESTA CLASIFICACIÓN ES VÁLIDA SOLO PARA EQUIPOS QUE FUNCIONAN CON BATERÍA.  
CLASSE DE ISOLAMENTO, ESTA CLASSIFICAÇÃO APENAS É VÁLIDA PARA OS APARELHOS QUE FUNCIONAM A BATERIA.



DIRECT CURRENT SYMBOL  
SYMBOLE COURANT CONTINU  
SIMBOLO CORRIENTE CONTINUA  
SÍMBOLO DE CORRENTE CONTÍNUA



	CE
	
Model :	Ser.N :
Vac :	Date :
W :	IP :
A :	Kg :
Hz :	

Fig.1

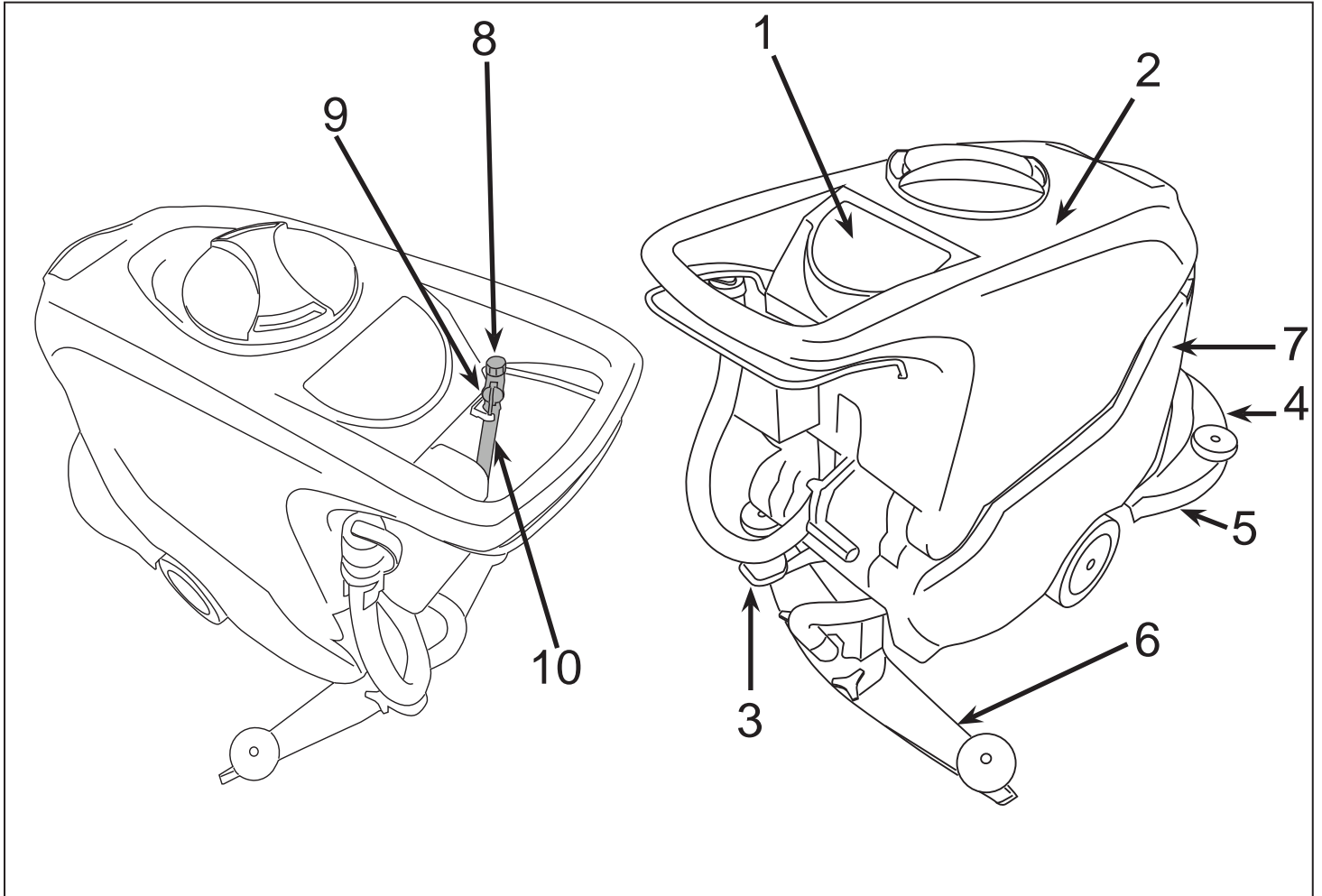

Fig.2

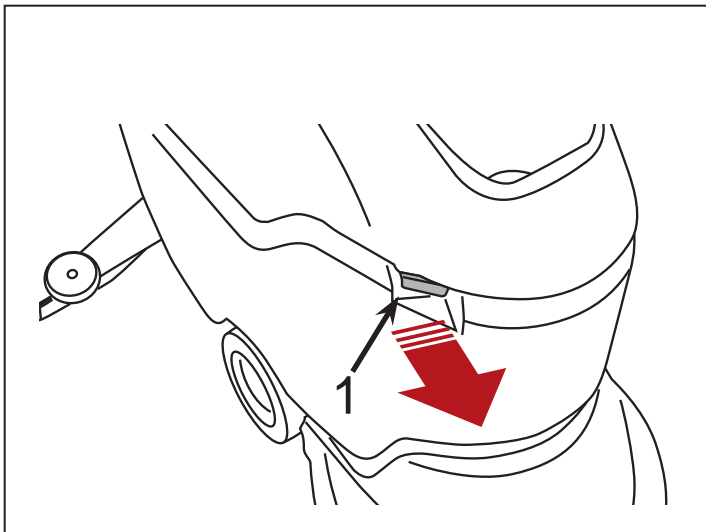

Fig.3

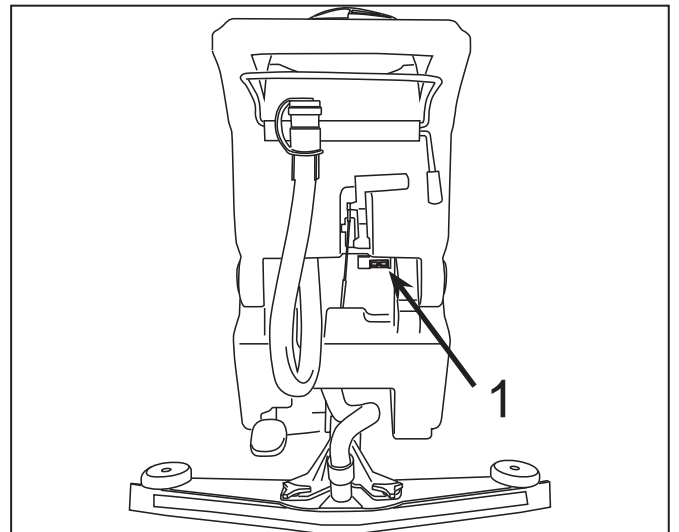

Fig.4

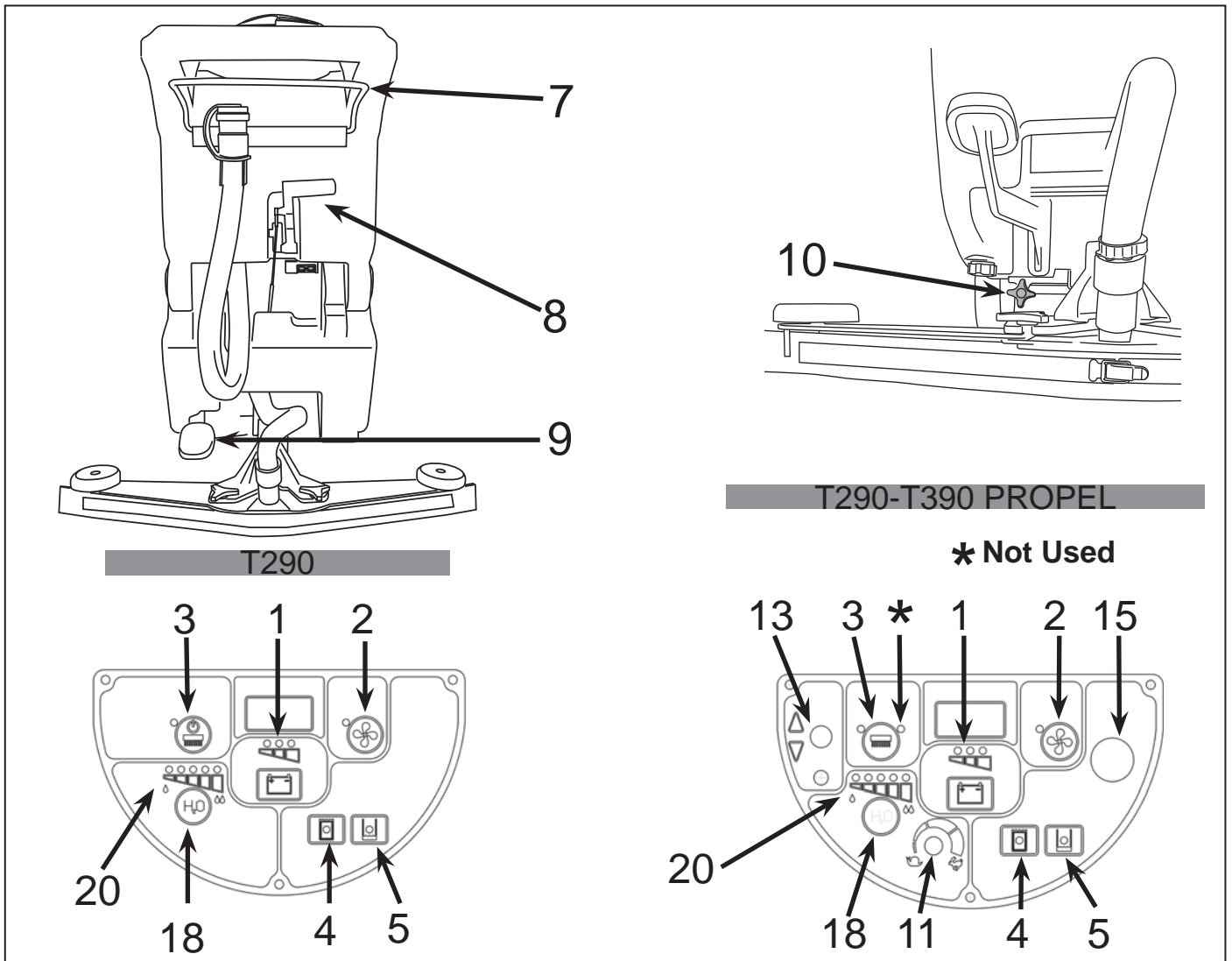

Fig.5

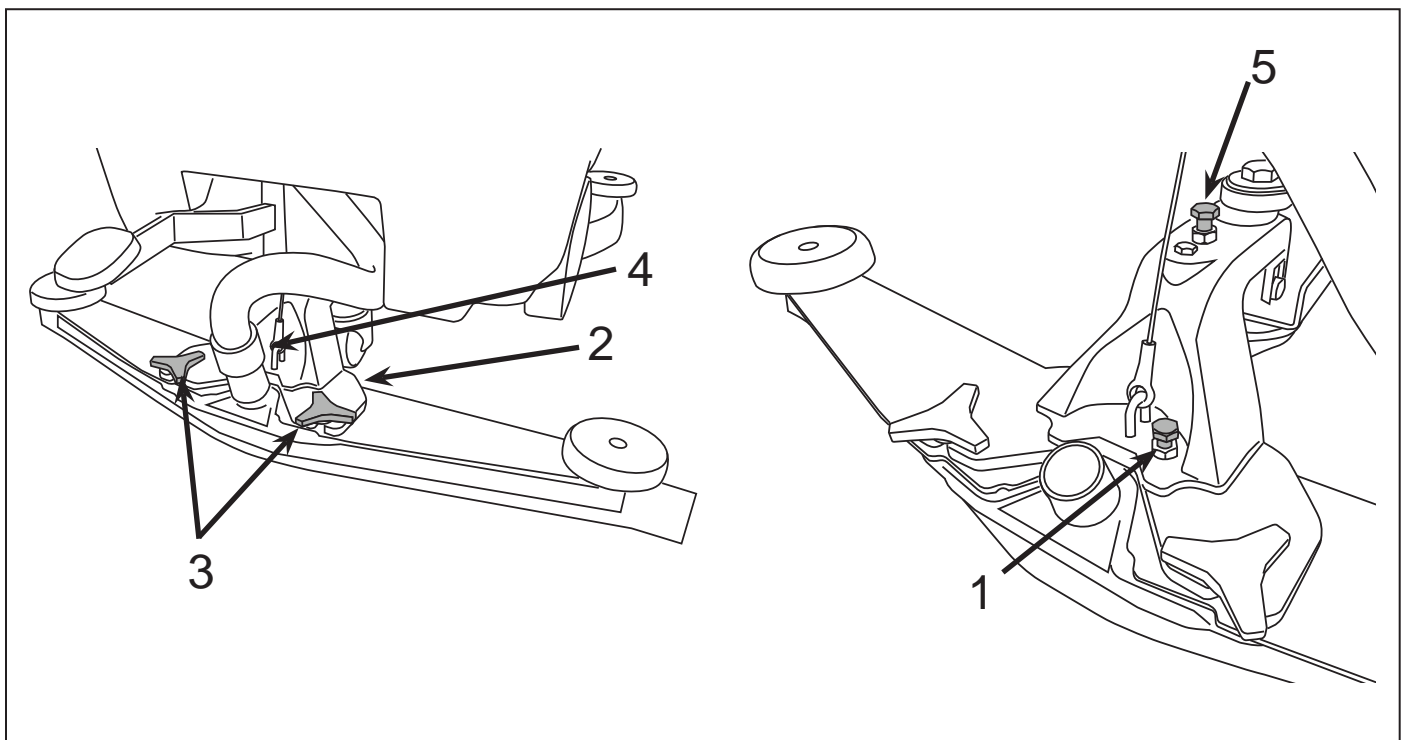

Fig.6

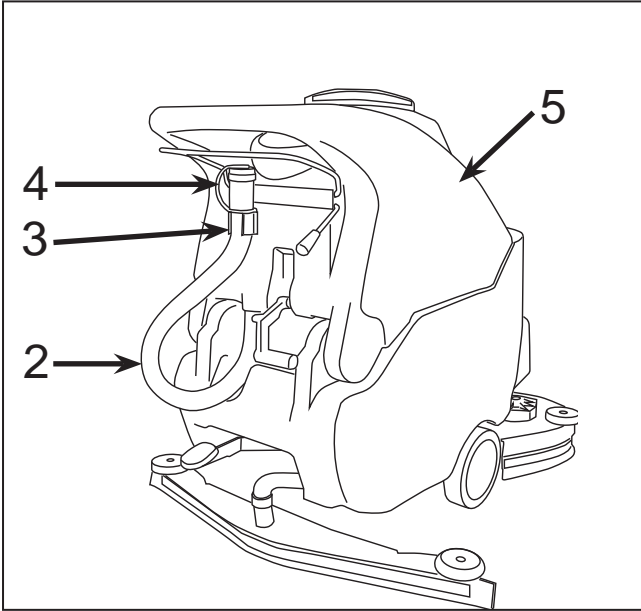

Fig.7

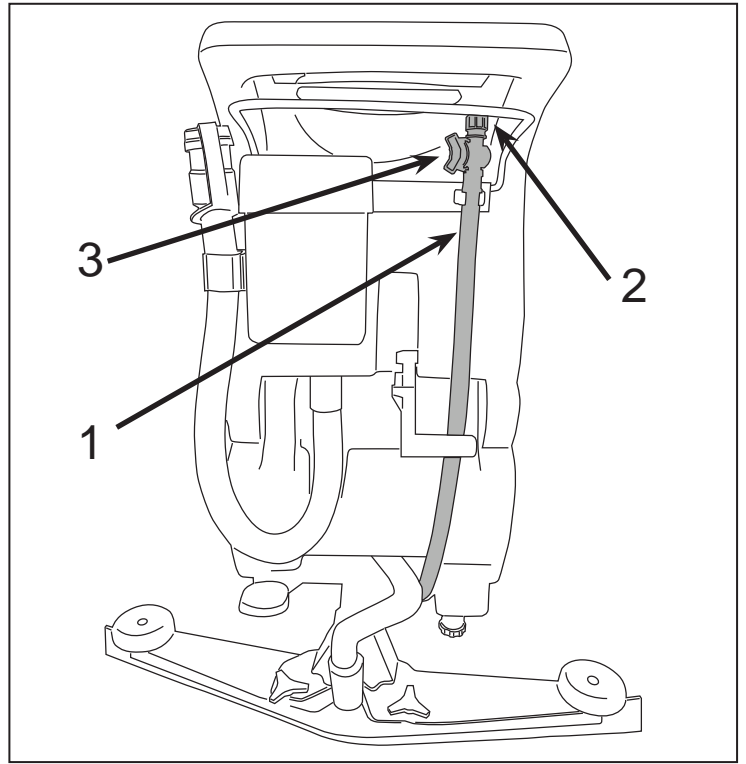

Fig.8

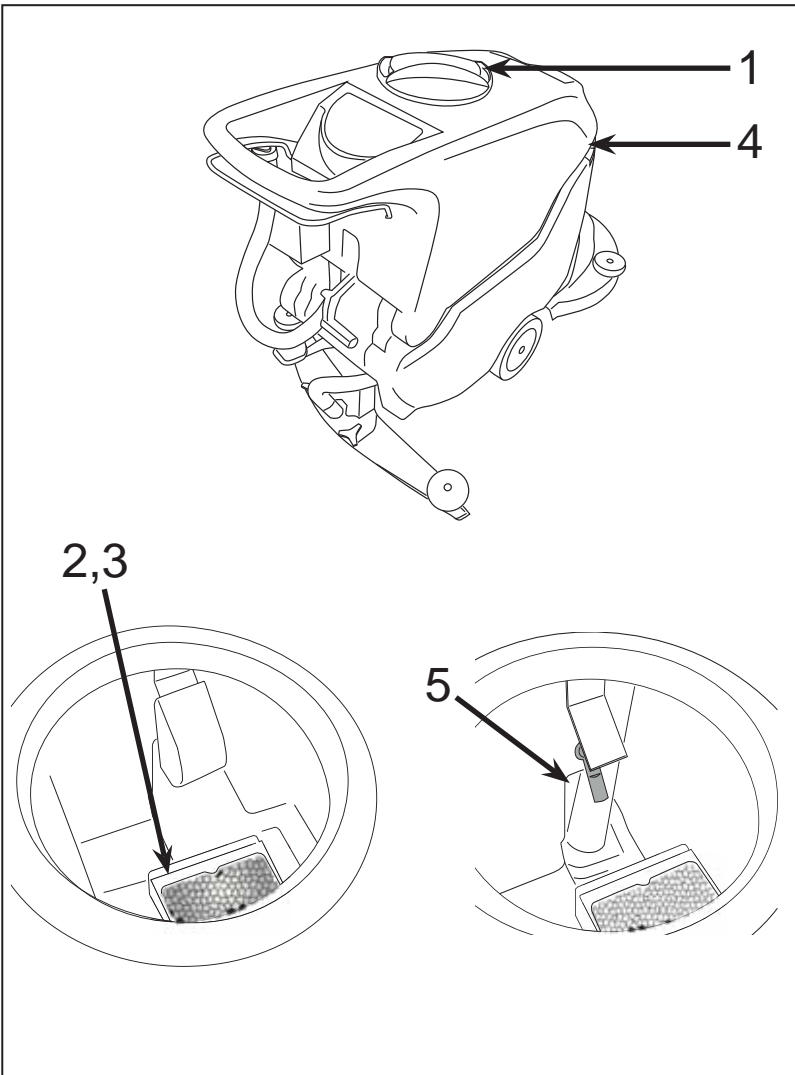

Fig.9

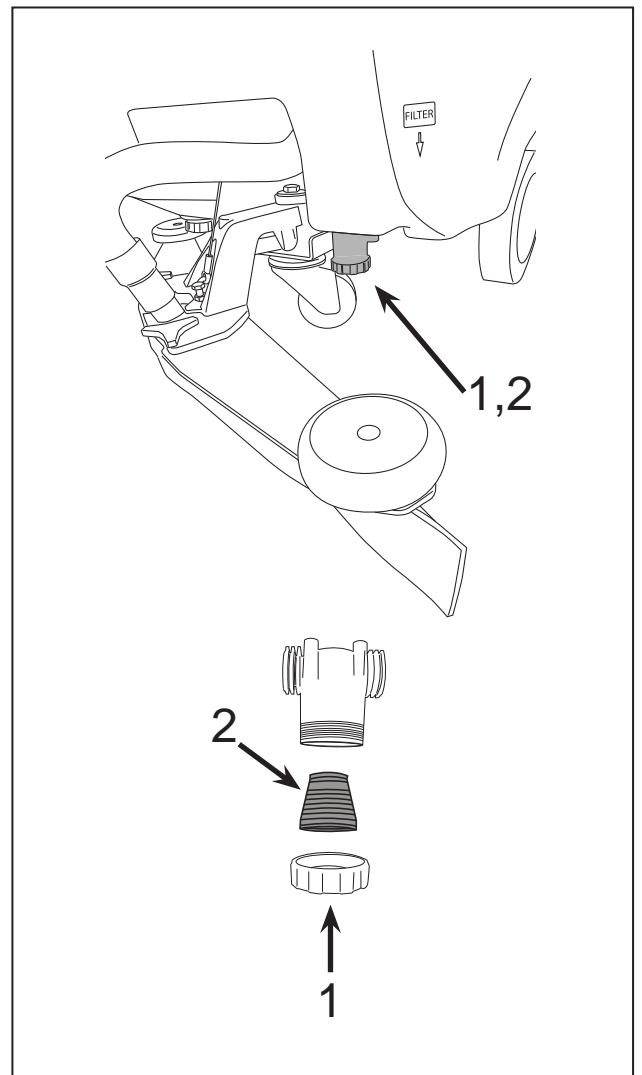

Fig.10

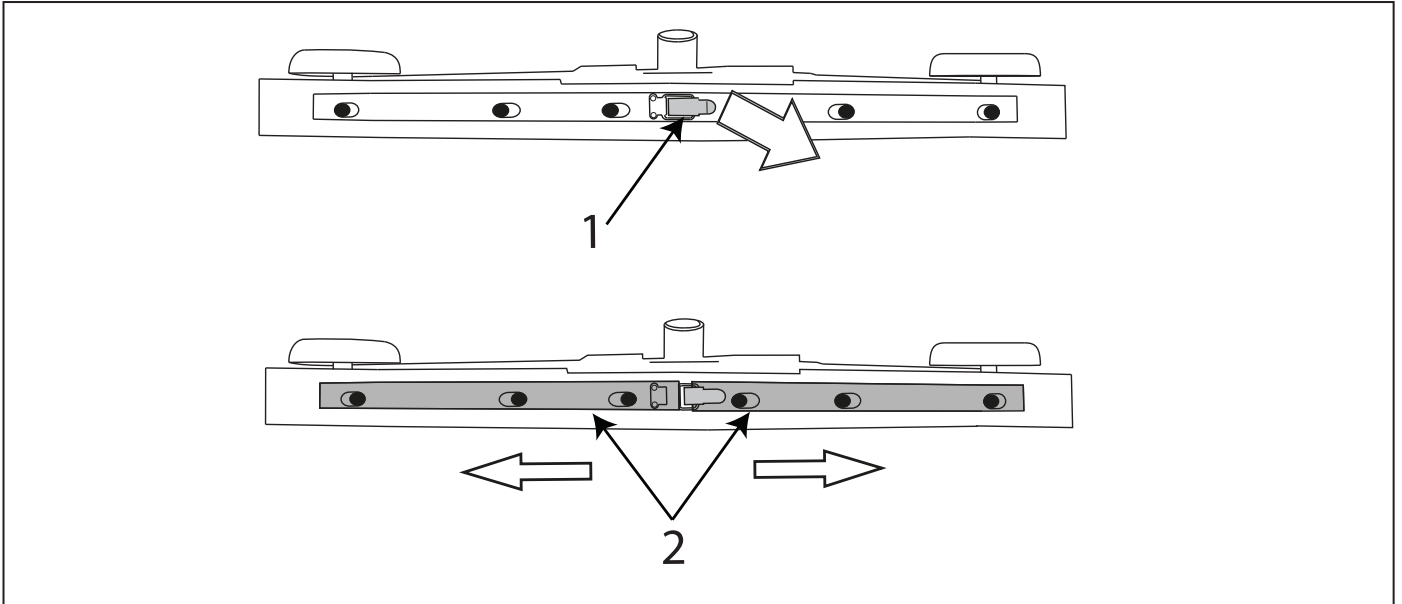

Fig.11

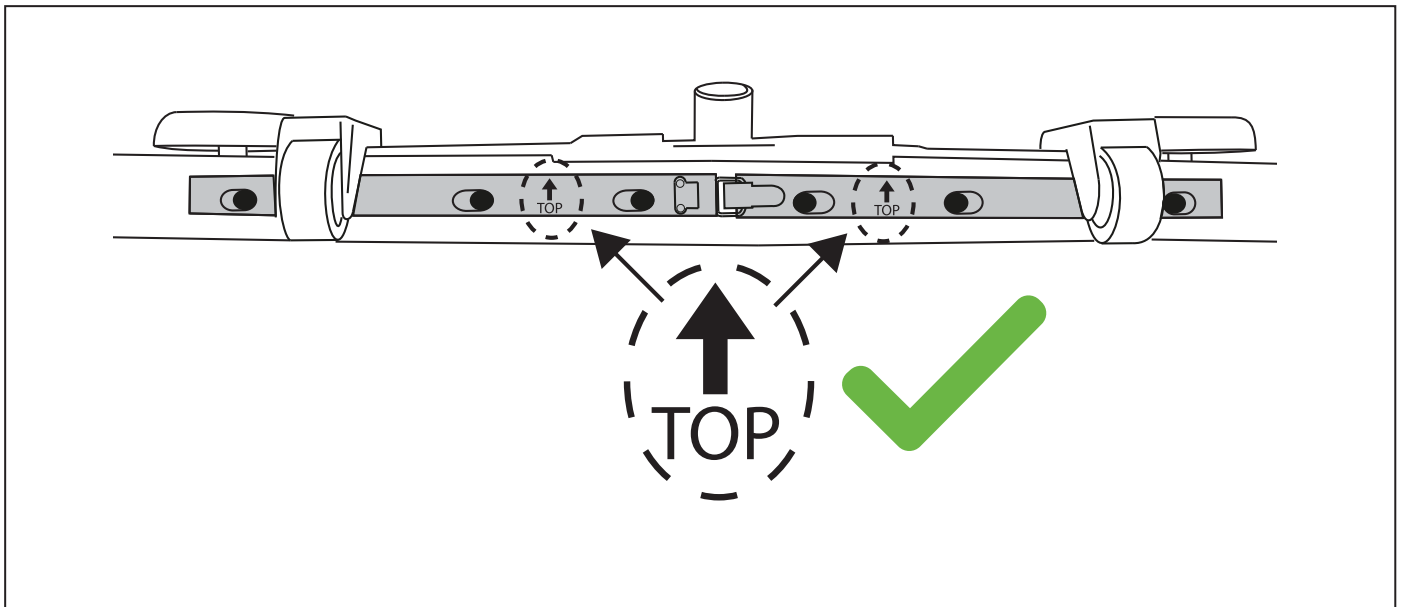

Fig.11 A

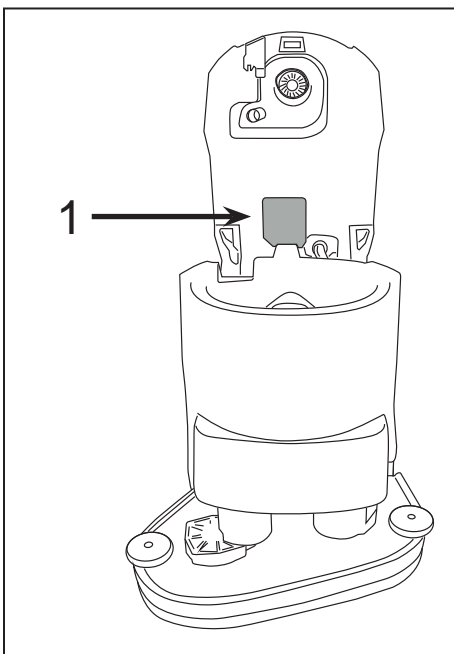

Fig.12

***ENGLISH***

*(Translated instructions)*

# 1. INDEX

<b>1. INDEX</b> .....	<b>2</b>
<b>2. GENERAL INFORMATION</b> .....	<b>3</b>
2.1. PURPOSE OF THIS MANUAL.....	3
2.2. IDENTIFYING THE MACHINE .....	4
2.3. DOCUMENTATION PROVIDED WITH THE MACHINE.....	4
<b>3. TECHNICAL INFORMATION</b> .....	<b>4</b>
3.1. GENERAL DESCRIPTION.....	4
3.2. PARTS OF THE MACHINE.....	4
3.3. DANGER ZONES.....	5
3.4. ACCESSORIES.....	5
<b>4. SAFETY INFORMATION</b> .....	<b>5</b>
4.1. SAFETY PRECAUTIONS .....	5
<b>5. MOVEMENT INSTALLATION</b> .....	<b>8</b>
5.1. LIFTING AND TRANSPORTING THE PACKAGED MACHINE .....	8
5.2. DELIVERY CHECKS.....	8
5.3. UNPACKING .....	8
5.4. ELECTRICAL CONNECTIONS AND EARTH (CABLE MODELS).....	8
5.5. POWER SUPPLY BATTERIES (BATTERY MODELS) .....	9
5.6. BATTERY CHARGER (BATTERY MODELS) .....	11
5.7. LIFTING AND TRANSPORTING THE MACHINE .....	11
<b>6. PRACTICAL GUIDE FOR THE OPERATOR</b> .....	<b>12</b>
6.1. CONTROLS - DESCRIPTION .....	12
6.2. MOUNTING AND ADJUSTING THE SQUEEGEE .....	13
6.3. MOVING THE MACHINE WHEN NOT IN OPERATION.....	13
6.4. MOUNTING AND CHANGING THE BRUSH/DRIVE DISKS .....	14
6.5. DETERGENTS - INSTRUCTIONS .....	14
6.6. FILLING THE WATER/DETERGENT TANK .....	15
6.7. PREPARING THE MACHINE FOR WORK .....	15
6.8. WORKING .....	15
6.9. SOME USEFUL TIPS TO GET THE MOST FROM YOUR SCRUBBER DRIER .....	16
6.10. DRAINING THE DIRTY WATER.....	17
6.11. DRAINING THE CLEAN WATER.....	17
<b>7. PERIODS OF INACTIVITY</b> .....	<b>17</b>
<b>8. BATTERY MAINTENANCE AND CHARGING</b> .....	<b>18</b>
8.1. CHARGING PROCEDURE.....	18
8.2. ON BOARD CHARGER SETTING INSTRUCTIONS .....	18
<b>9. MAINTENANCE INSTRUCTIONS</b> .....	<b>20</b>
9.1. MAINTENANCE - GENERAL RULES .....	20
9.2. ROUTINE MAINTENANCE .....	20
9.3. ROUTINE MAINTENANCE .....	21
9.4. MAINTENANCE .....	22
<b>10. TROUBLESHOOTING</b> .....	<b>23</b>
10.1. HOW TO RESOLVE POSSIBLE PROBLEMS .....	23
<b>11. DISPLAY ALARMS</b> .....	<b>27</b>
<b>12. T290 - RECOMMENDED SPARE PARTS</b> .....	<b>28</b>
<b>13. T390 - RECOMMENDED SPARE PARTS</b> .....	<b>28</b>

## 2. GENERAL INFORMATION



**Read this manual carefully before carrying out any work on the machine<sup>1</sup>.**

### 2.1. Purpose of this manual

This manual has been written by the Manufacturer and is an integral part of the machine. It defines the purpose for which the machine has been designed and constructed and contains all the information required by operators<sup>2</sup>.

In addition to this manual containing all user information, other publications are available providing specific information for maintenance personnel<sup>3</sup>.

Constant compliance with the instructions provided in this manual guarantees the safety of the operator and the machine, ensures low running costs and high quality results and extends the working life of the machine. Failure to follow these instructions may lead to injury to the operator or damage to the machine, floor and environment.

Consult the table of contents at the beginning of the manual to find the section you need rapidly.

Parts of the text requiring special attention are printed in bold and preceded by the symbols illustrated and described here.

### **! DANGER**

**Indicates the need for attention in order to avoid a series of consequences which could cause death or serious injury to personnel.**

### **👉 IMPORTANT**

**Indicates the need for attention in order to avoid a series of consequences which could cause injury to personnel or damage to the machine or work environment or financial loss.**

### **i INFORMATION**

**Indicates particularly important instructions.**

In line with the company's policy of constant product development and updating, the Manufacturer reserves the right to make modifications without prior notice.

Although your machine may differ appreciably from the illustrations in this document, the correctness and validity of the instructions contained in this manual are guaranteed.

---

<sup>1</sup> The definition "machine" replaces the trade name covered by this manual.

<sup>2</sup> Persons responsible for using the machine without performing any operations requiring precise technical skills.

<sup>3</sup> Persons with experience, technical training and a knowledge of legislation and standards, able to perform all the necessary operations and to recognise and avoid possible risks in handling, installation, use and maintenance of this machine.

## 2.2. Identifying the machine

The rating plate (fig. 1) provides the following information:

- model code;
- model;
- power supply;
- total nominal power;
- serial number;
- year of fabrication;
- dry weight;
- maximum slope;
- barcode with serial number;
- manufacturer's identification.

## 2.3. Documentation provided with the machine

- Operator's manual
- Guarantee certificate;
- Charger Manual.
- Wall Chart

# 3. TECHNICAL INFORMATION

## 3.1. General description

This machine is a scrubber drier for sweeping, washing and drying flat, horizontal, smooth or moderately rough, even and obstacle free floors in civil and industrial premises. It is available in both battery and cable versions to meet all running time and weight requirements.

The scrubber drier spreads a solution of water and detergent in the correct concentration on the floor and then scrubs it to remove the dirt. By carefully choosing the detergent and brushes (abrasive disks or rollers) from the wide range of accessories available, the machine can be adapted to a wide range of combinations of types of floor and dirt.

A suction system incorporated in the machine dries the floor after washing by means of the low pressure generated in the dirty water tank by the suction motor. The squeegee connected to the tank collects the dirty water.

The machine is moved forward by:

**MODEL B mechanical drive:** the scrubber drier is provided with a special mechanical drive device which exploits the friction between the brush and the floor to generate a forward movement (for further details, see paragraph 6.7).

MODEL BT electric drive: the scrubber drier is moved forward by means of a special electromechanical drive device.

## 3.2. Parts of the machine

The main parts of the machine are as follows (fig. 2):

- the detergent tank (fig. 2, ref. 7): contains and transports the mixture of clean water and detergent;
- the dirty water drum (fig. 2, ref. 2): collects the dirty water picked up from the floor after washing;
- control panel (fig. 2, ref. 1);
- head assembly (fig. 2, ref. 4): the main element is the brushes/rollers (fig. 2, ref. 5) which distribute the detergent solution on the floor and remove the dirt;
- squeegee assembly (fig. 2, ref. 6): wipes and dries the floor by collecting the water.
- head lift pedal (fig. 2, ref. 3): raises the brush head during transport.

### 3.3. Danger zones

- A -Tank assembly: when using certain detergents, danger of irritation for eyes, skin, mucous membranes and respiratory tract and of asphyxia. Danger represented by the dirt collected from the environment (germs and chemical substances). Danger of crushing between the two tanks when the dirty water tank is replaced on top of the detergent tank.
- B -Control panel: risk of injury from short circuits.
- C -Bottom of washing head: danger due to brush rotation.
- D -**Rear wheels**: danger of crushing between the wheel and chassis.
- E -**Battery compartment** (in the detergent tank): danger of short circuit between the battery poles and presence of hydrogen during charging.

### 3.4. Accessories

- **Bristle brushes**: for washing delicate floors and polishing;
- **Polypropylene brushes**: for normal floor washing;
- **Drive disks**: enable the following disks to be used:
  - \* Yellow disks: for washing and polishing marble and similar surfaces;
  - \* Green disks: for washing resistant floors;
  - \* Black disks: for thorough washing of resistant floors with stubborn dirt.
- **S.P.E. CBHD1 / CBHD1-XR-P battery charger**

## 4. SAFETY INFORMATION

### 4.1. Safety precautions



**Read this Operator's Manual carefully before start-up and use and before performing any maintenance or other work on the machine.**

### **IMPORTANT**

**Rigorously respect all instructions in the Manual (in particular those relating to danger and important information) and on the safety plates fitted to the machine. The Manufacturer declines all liability for damage to people or things resulting from failure to observe the instructions.**

The appliance must be used exclusively by persons trained in its use and/or who have demonstrated their ability and have been expressly instructed to use the appliance.

The machine must not be used by minors.

The machine must not be used for purposes other than those for which it was expressly designed. Scrupulously respect all safety standards and conditions applicable to the type of building in which the machine is to be operated (e.g.: pharmaceutical companies, hospitals, chemicals, etc.).

This machine is intended for use in commercial applications, such as hotels, schools, hospitals, factories, shops and offices, or for hire.

Do not use the machine in inadequate lighting, explosive atmospheres, on public roads, to clean dirt that is hazardous to health (dust, gas, etc.) or in unsuitable environments.

The machine must only be used indoors.

The machine is designed to operate in temperatures between +4°C and +35°C (39.2°F and 95°F). It can be stored in temperatures between +0°C and +50°C (32°F and 122°F) when not in use.

The machine is designed to operate at relative humidity levels between 0% and 95%.

Warning, the machine must be kept indoors at all times.

Never use or pick up flammable liquids or explosives (e.g. petrol, fuel oil, etc), flammable gases, dry dusts, acids and solvents (e.g. paint solvents, acetone etc) even if diluted. Never pick up flaming or incandescent objects.

Never use the machine on slopes or ramps of more than 2%. In the case of slight slopes, do not use the machine transversally, always manoeuvre with care and do not reverse. When transiting steeper ramps or slopes, take the utmost care to prevent tipping and/or uncontrolled acceleration. Move the machine on ramps and/or steps only with the brush head and squeegee raised.

**Never park the machine on a slope.**

Never leave the machine unattended with the motor or engine on. Before leaving it, turn the motor or engine off and make sure it cannot move accidentally.

Always pay attention to other people, children in particular, present in the place where you are working.

Children must be supervised to make sure they do not play with the machine.

The machine is not intended for use by persons (including children) with reduced physical, sensory or mental capabilities, or lack of experience and knowledge, unless they are supervised by a person responsible for their safety and have received instruction in the use of the machine.

Never use the machine to transport people or goods or to tow things. Do not tow the machine.

Never rest objects of any weight on the machine for any reason.

Never obstruct the ventilation and heat dispersion openings.

Never remove, modify or circumvent safety devices.

Numerous unpleasant experiences have shown that a wide range of personal objects may cause serious accidents. Before beginning work, remove jewellery, watches, ties, etc.

The operator must always use personal protection devices - protective apron or overalls, non-slip waterproof shoes, rubber gloves, protective goggles and ear protectors and mask to protect the respiratory tract.

Keep hands away from moving parts.

Never use detergents other than those specified. Follow the instructions on the relative safety sheet. We recommend keeping detergents out of reach of children. In the event of contact with the eyes, wash immediately with abundant water. If ingested, consult a doctor immediately.

Make sure the power sockets used for the models with cable or battery charger are connected to a suitable earth system and protected by differential thermal solenoid switches.

Make sure the electrical characteristics of the machine (voltage, frequency, absorbed power) given on the rating plate (fig. 1) are the same as those of the mains electricity supply. The machine with cable has a three-wire cable and a three pin earthed plug for use in an appropriate earthed socket. The earth wire is yellow and green. Never connect this wire to anything other than the earth contact of the socket.

It is indispensable to respect the battery manufacturer's instructions and applicable legislation. The batteries should always be kept clean and dry to avoid surface leakage current. Protect the batteries from impurities such as metal dust.

Never rest tools on the batteries as they could cause short circuits leading to explosions.

When using battery acid, always follow the relative safety instructions scrupulously.

When using cable-powered versions, make sure to avoid crushing or tearing the power cable, and make sure the rotating brush does not come into contact with the power cable.

Check the power cable regularly. If damaged, do not under any circumstances use the machine. For replacement, contact a specialised service centre.

To recharge the batteries, always use the battery charger supplied with the machine (when provided).

If particularly strong magnetic fields are present, assess their possible effect on the control electronics.

Never wash the machine with water jets.

The fluids collected contain detergent, disinfectant, water and organic and inorganic material. They must be disposed off in accordance with current legislation.

In the case of malfunction and/or faulty operation, turn the machine off immediately (disconnecting it from the mains power supply or batteries) and do not tamper. Contact a service centre authorised by the Manufacturer.

All maintenance operations must be performed in an adequately lit place and only after disconnecting the machine from the power supply, in cable models by unplugging the machine from the socket, in battery models by disconnecting the battery connector.

All work on the electrical system and all maintenance and repair operations other than those explicitly described in this manual must be performed by specialised personnel expert in the sector only.

If the power cable, plug or terminals require replacing, make sure the electrical connections and cable grip inside the control panel are tightly fastened to guarantee the resistance of the cable if pulled. Then replace the panel carefully to guarantee the safety of the operator.

Only original accessories and spare parts supplied by the Manufacturer may be used in order to guarantee safe problem-free operation of the machine. Never use parts removed from other machines or from other kits.

This machine has been designed and constructed to provide ten years' service from the fabrication date shown on the rating plate (fig. 1). After this period, whether the machine has been used or not, it should be disposed of according to current legislation in the country in which it is used.

- the machine must be disconnected from the power supply, emptied of liquids and cleaned;
- the product is classified as WEEE type special waste and is covered by the requisites of the new environmental protection regulations (2002/96/EC WEEE). It must be disposed of separately from ordinary waste in compliance with current legislation and standards.

**Special waste. Do not dispose of with ordinary waste.**

Alternatively, return the machine to the Manufacturer for a complete overhaul.

If you decide to stop using the machine, remove the batteries and dispose of them through an authorised recycling centre.

Also make sure that all parts of the machine that could represent a hazard, particularly to children, are made safe.



## 5. MOVEMENT INSTALLATION

### 5.1. Lifting and transporting the packaged machine

#### IMPORTANT

**During all lifting operations, make sure the packaged machine is firmly secured to avoid it tipping up or being accidentally dropped.**

**Always load/unload lorries in adequately illuminated areas.**

The machine is packaged on a wooden pallet by the Manufacturer. It must be loaded on to the transporting vehicle using suitable equipment (see EC Directive 89/392 and subsequent amendments and/or additions). At destination, it must be unloaded using similar means.

The squeegees are packed in cardboard boxes without pallet.

A fork lift truck must always be used to lift the packaged body of the machine. Handle with care to avoid knocking or overturning the machine.

### 5.2. Delivery checks

When the carrier delivers the machine, make sure the packaging and machine are both whole and undamaged. If the machine is damaged, make sure the carrier is aware of the damage and before accepting the goods, reserve the right (in writing) to request compensation for the damage.

### 5.3. Unpacking

#### IMPORTANT

**When unpacking the machine, the operator must be provided with the necessary personal protection devices (gloves, goggles, etc.) to limit the risk of injury.**

Proceed as follows to unpack the machine.

- cut and remove the plastic straps using scissors or nippers;
- remove the cardboard;
- remove the bags in the battery compartment (in the detergent tank) and check the contents:
  - guarantee slip;
  - use and maintenance manual;
  - battery bridges with terminals (battery model only);
  - battery charger connector (battery models only);
- depending on the model, remove the metal brackets or cut the plastic straps fixing the machine chassis to the pallet;
- using a sloping ramp, push the machine backwards off the pallet;
- unpack the brushes and squeegees;
- clean the outside of the machine in respect of safety regulations;
- after unpacking the machine, install the batteries (battery models) or connect the electrical connections (cable models). See relevant sections.

The packaging may be kept and reused to protect the machine if it is moved to another site or to a repair workshop.

Otherwise it must be disposed of in compliance with current legislation.

### 5.4. Electrical connections and earth (cable models)

The electrical characteristics of the machine are given on the rating plate (fig. 1). Make sure the frequency and voltage correspond to those of the mains supply where the machine will be operated. Make sure the frequency and voltage correspond to those of the mains supply where the machine will be operated. As far as voltage is concerned, models where the rating plate specifies a voltage of 230 V can be used with voltages of

between 220 V and 240 V. Similarly, models rated at 115 V can be used at between 110 V and 120 V. The frequency on the plate must always correspond to the mains voltage.

## IMPORTANT

**Make sure the mains circuit is suitably earthed and that the sockets (and any adaptors used) ensure the continuity of the earth conductors.**

## ! DANGER

**Failure to observe these instructions could cause possibly serious damage to people and things and invalidates the guarantee.**

### 5.5. Power supply batteries (battery models)

Two different types of battery may be installed on these machines:

- tubular leak-proof batteries: the electrolyte level must be checked regularly. When necessary, top up with distilled water until the plates are covered. Do not over-fill (5 mm max. above the plates).
- gel batteries: this type of battery requires no maintenance.

The technical characteristics must correspond to those indicated in the paragraph on the technical specification of the machine. The use of heavier batteries could seriously jeopardise manoeuvrability and lead to the brush motor overheating. Batteries with a lower capacity and weight will require charging more frequently.

Batteries must be kept charged, dry and clean and the connections must be kept tight.

## i INFORMATION

Follow the instructions below to configure the machine's software for the type of batteries installed:

### **Mechanical drive version (B):**

- turn the machine on by pressing the button (fig. 5, ref. 3), wait 5 seconds and make sure the display comes on.
- press the brush buttons (fig. 5, ref. 3) and suction button (fig. 5, ref. 2) together for at least 5 seconds. This accesses the battery setting menu.
- press the suction button (fig. 5, ref. 2) to select the type of battery installed on the machine "ACd" for acid batteries (tubular leak-proof batteries) or "GEL" (GEL batteries).
- Press together the buttons (fig. 5 ref. 2) and (fig. 5 ref. 3) for least 5 seconds, to save the changes and exit.

**Electric drive version (BT):** set the machine software to the type of battery installed, following this sequence:

- turn the machine on by turning the emergency button key switch (fig. 5, ref. 15), wait 5 seconds and make sure the display comes on.
- press the brush buttons (fig. 5, ref. 3) and suction button (fig. 5, ref. 2) together for at least 5 seconds. This accesses the battery setting menu.
- press the suction button (fig. 5, ref. 2) to select the type of battery installed on the machine "ACd" for acid batteries (tubular leak-proof batteries) or "GEL" (GEL batteries).
- Press together the buttons (fig. 5 ref. 2) and (fig. 5 ref. 3) for least 5 seconds, to save the changes and exit .

### 5.5.1. Batteries: preparation

## ! DANGER

During installation of the batteries or any type of battery maintenance, the operator must be provided with the necessary personal protection devices (gloves, goggles overalls, etc) to limit the risk of accident. Keep away from naked flames, avoid short circuiting the battery poles, avoid sparks and do not smoke.

Batteries are normally supplied filled with acid and ready for use.

If the batteries are dry, proceed as follows before installing them in the machine.

- remove the caps and fill all elements with specific sulphuric acid solution until the plates are entirely covered (this requires at least a couple of passes for each element);
- leave for 4-5 hours to allow the air bubbles to come to the surface and the plates to absorb the electrolyte;
- make sure the level of electrolyte is still above the plates and if necessary top up with sulphuric acid solution;
- close the caps;
- mount the batteries on the machine (following the procedure described below).

Before starting up the machine for the first time, charge the batteries as follows.

### 5.5.2. Batteries: installation and connection

## ! DANGER

Check that all switches on the control panel are in the "0" (off) position.

Make sure you connect the terminals marked with a "+" to the positive poles of the battery. Do not check the battery charge by sparking.

Meticulously follow the instructions given below as short circuiting the batteries could cause them to explode.

- Make sure the two tanks are empty (if necessary, empty them. See the relevant paragraph).
- Release the dirty water drum (fig. 2, ref. 2) from the detergent tank (fig. 2, ref. 7) by pulling the catch (fig. 3, ref. 1).
- Lift the dirty water drum and tilt it backwards by about 90°. This provides access to the battery compartment (in the detergent tank) from above.
- Place the batteries in the compartment in the direction shown in the drawing printed inside the compartment on the detergent tank.

## 👉 IMPORTANT

Mount the batteries on the machine using lifting means suitable for their weight. The positive and negative poles have different diameters.

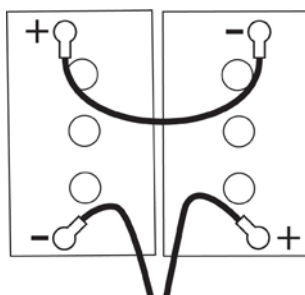

- Referring to the wiring layout shown in the above diagram, connect the battery cable and bridge terminals to the battery poles. Arrange the cables as shown in the diagram, tighten the terminals on the poles and cover with Vaseline.
- Lower the dirty water drum into its work position and fasten it to the detergent tank;
- When using the machine, follow the instructions below.

### 5.5.3. Batteries: removal

## ! DANGER

When removing the batteries, the operator must be equipped with suitable personal protection devices (gloves, goggles, overalls, safety shoes, etc) to reduce the risk of accidents. Make sure the switches on the control panel are in the "0" position (off) and the machine is turned off. Keep away from naked flames, do not short circuit the battery poles, do not cause sparks and do not smoke. Proceed as follows:

- disconnect the battery wiring and bridge terminals from the battery poles.
- if necessary, remove the devices fixing the battery to the base of the machine.
- lift the batteries from the compartment using suitable lifting equipment.

### 5.6. Battery charger (battery models)

## IMPORTANT

Never allow the batteries to become excessively flat as this could damage them irreparably.

#### 5.6.1. Choosing a battery charger

Make sure the battery charger is compatible with the batteries to be charged:

- tubular lead batteries: you are recommended to use a 24V - 20 A automatic battery charger. However, you should always consult the battery charger manufacturer and manual to confirm the choice.
- gel batteries: use a charger specific for this type of battery.

#### 5.6.2. Preparing the battery charger

If you wish to use a battery charger not provided with the machine, you must fit it with the connector supplied with the machine (see paragraph "Unpacking" in this manual).

The connector supplied for the external battery charger is suitable for cables with a minimum cross-section of 4 mm<sup>2</sup>

Proceed as follows to fit the connector.

- Remove about 13 mm of protective sheath from the red and black cables of the battery charger.
- Insert the wires into the connector contacts and squeeze them forcefully with suitable pliers.
- Respect the polarity (red wire + black wire -) when inserting the wires into the connector.

### 5.7. Lifting and transporting the machine

## IMPORTANT

All phases of lifting and moving must be performed in an adequately illuminated environment with the adoption of the safety measures most appropriate to the situation.

The operator must always use personal protection devices.

To load the machine onto a means of transport, proceed as follows:

- empty the dirty water and detergent tanks;
- remove the squeegee and brushes or drive disks;
- remove the batteries;
- place the machine on the pallet and fix it with plastic straps or metal brackets;

- lift the pallet (with the machine) using a fork lift truck and load it onto the means of transport;
- anchor the machine to the means of transport with cables connected to the pallet and machine itself.

## 6. PRACTICAL GUIDE FOR THE OPERATOR

### 6.1. Controls - Description

With reference to fig. 5, the machine has the following controls and indicator lights:

- **Battery charge light** (fig. 5, ref. 1): consists of 3 LEDs (red, yellow and green) which indicate the level of battery charge. There may be:
  - a) green LED on: batteries from 100% to 50% charged;
  - b) yellow LED on: batteries from 50% to 18% charged;
  - c) red LED on: batteries almost flat;
  - d) **red LED flashing**: batteries completely flat; after a few seconds the brushes stop and the brush switch light also comes on.
- **Main key switch - emergency button** (fig. 5, ref. 15 BT models with electric drive): enables and disables power to all machine functions. Acts as a safety device. To start up the machine, turn the key clockwise. To stop the machine press the button.
- **Main Switch** (fig. 5, ref. 3 B models with mechanical drive): enables and disables electrical power to all machine functions. To start the machine press the button. To stop the machine press the button.
- **Brush button with light** (fig. 5, ref. 3 - **all models**): enables (LED on) and disables (LED off) brush and suction motor operation.
- **Suction button with light** (fig. 5, ref. 2): switches the suction motor responsible for drying the floor being washed on ("LED on") or off ("LED off"). The light is on when there is power to the suction motor.
- **Solution flow regulation button** (fig. 5, ref. 18): enables the flow of detergent to the brushes to be regulated constantly. The quantity of liquid delivered is indicated by the LEDs (fig. 5, ref. 20).

Holding this button down for at least 2 seconds enables/disables detergent flow.

On this machine, the quantity of flow delivered can be adjusted manually by pressing the detergent flow regulation button (fig. 5, ref. 18) a number of times or automatically (**BT models with electric drive only**). In this mode, the flow delivered will automatically be in proportion to machine speed. Follow the instructions below to set the machine's software for the type of detergent flow:

- turn the machine on, wait 5 seconds and make sure the display comes on.
- press the brush buttons (fig. 5, ref. 3) and suction button (fig. 5, ref. 2) together for at least 5 seconds. This accesses the battery setting menu.
- press the brush button (fig. 5, ref. 3) once to access the water regulation menu ("MAN" or "AUT" appears on the display).
- press the suction button (fig. 5, ref. 2) a number of times to select "MAN" (manual) or "AUT" (automatic) operating mode.
- memorise the displayed parameter by pressing the emergency or brush button.
- **Drive lever** (fig. 5, ref. 7): the drive lever moves the machine forwards and rotates the brushes.
- **Squeegee lever** (fig. 5, ref. 8): raises (if lowered) or lowers (if raised) the squeegee.

- **Direction adjustment knob** (fig. 5, ref. 10): turn to correct any deviation of the machine from a straight line.
- **Head lowering/raising pedal** (fig. 5, ref. 9): on the left side of the machine, when pressed it lowers/raises the brush head.
- Detergent tank level indicator (fig. 5, ref. 5): the LED comes on when there is no longer sufficient water in the detergent tank.
- Dirty water drum level indicator (fig. 5, ref. 4): when the dirty water drum is full the LED comes on and after a few seconds the suction motor shuts down.
- **Display**: displays any alarms active. During normal operation, it displays the hour counter (giving the actual number of hours the machine has been operating).
- **Direction selection** (fig. 5, ref. 13 - **BT models with electric drive**): sets movement of the machine to forwards or reverse.
- **Speed control potentiometer** (fig. 5, ref. 11 - **BT models with electric drive**), turning the potentiometer sets the maximum machine speed.

## 6.2. Mounting and adjusting the squeegee

The squeegee (fig. 6) is responsible for the first phase of drying.

To mount the squeegee on the machine, proceed as follows:

- check that the squeegee mount (fig. 6, ref. 2) is raised, otherwise lift it by means of the squeegee lever (fig. 5, ref. 8);
- insert the suction hose sleeve (fig. 6, ref. 4) fully into the squeegee;
- slacken the two knobs (fig. 6, ref. 3) at the centre of the squeegee;
- insert the two threaded pins into the slots on the support (fig. 6, ref. 2);
- fix the squeegee by tightening the two knobs (fig. 6, ref. 3).

The squeegee blades scrape the film of water and detergent from the floor and prepare the way for perfect drying. With time, the constant rubbing makes the edge of the blade in contact with the floor rounded and cracked, reducing the drying efficiency and requiring it to be replaced. The state of wear should be checked frequently.

For perfect drying, the squeegee must be adjusted in such a way that the edge of the rear blade bends during operation by about 45° with respect to the floor at every point. The angle of the blades can be adjusted using the screw (fig. 6, ref. 1), while the height of the squeegee from the floor can be adjusted using the screw (fig. 6, ref. 5).

## 6.3. Moving the machine when not in operation

Proceed as follows to move the machine.

- raise the squeegee;
- push the head pedal down then to the right (fig. 5 ref. 9) to raise the head;
- move the machine as follows:
  - Versions with mechanical drive: push or pull;
  - Versions with electric drive: to move the machine forwards, press the selector (fig. 5 ref. 13), then operate the drive lever (fig. 5 ref. 7). To move the machine backwards, press the selector (fig. 5 ref. 13), then operate the drive lever (fig. 5 ref. 7);  
speed can be varied by the potentiometer knob (fig. 5. ref. 11).
- once you have reached your destination, lower the head by pressing the release pedal (fig. 5 ref. 9) down and to the left, then release it.

### **WARNING!**

Do not leave the machine unattended or parked with the head lifted or the key inserted in the emergency button.

## 6.4. Mounting and changing the brush/drive disks

### IMPORTANT

**Never work without the brushes, rollers and drive disks perfectly installed.**

**Fitting the brush (one-brush models):** Rest the brush on the floor in front of the machine and centre it with the guard. Lower the head and repeatedly action the brush/drive control lever (fig. 5, ref. 7) until the brush automatically engages on the flange hub. If the manoeuvre is not successful, press on the handle again and repeat the centring and repeated actioning of the brush/drive lever.

Use of abrasive/microfibre disks: fit the abrasive/microfibre disk on the drive disk and perform the operations described for fitting the brush on the scrubber drier.

Removing the brush (one-brush models) (or drive disk):

Raise the machine head by pushing the head lift pedal down and then to the right (fig. 5, ref. 9) and repeatedly action the brush/drive lever. After a few pulses, the brush/es (or drive disk) is released and falls to the ground.

### ! DANGER

**These operations must be performed with the machine off.**

**Fitting the brushes (two brush models):**

Raise the machine head by pushing the head lift pedal down and then to the right (fig. 5, ref. 9).

Place the brushes under the head drive disk.

Lift the right brush with your hands and turn it clockwise, locking it in position on the drive disk. Lift the left brush with your hands and turn it anticlockwise, locking it in position on the drive disk.

Use of abrasive disks: fit the abrasive disk on the drive disk and perform the operations described for fitting the brush on the scrubber drier.

**Removing the brushes (two-brush models):**

Raise the machine head by pushing the head lift pedal down and then to the right (fig. 5, ref. 9). Turn the right brush anticlockwise, releasing it from the drive disk. Turn the left brush clockwise, releasing it from the drive disk.

## 6.5. Detergents - Instructions

### IMPORTANT

**Always dilute the detergent according to the manufacturer's instructions. Do not use sodium hypochlorite (bleach) or other oxidants, particularly in strong concentrations. Do not use solvents or hydrocarbons. The temperature of the water and detergent must not exceed the maximum indicated in the technical specification. They must be free of sand and/or other impurities.**

The machine has been designed for use with low-foam biodegradable detergents made specifically for scrubber driers.

For a complete and up-to-date list of the detergents and chemicals available, contact the Manufacturer:

Use products suitable for the floor and dirt to be removed only.

Follow the safety regulations on use of detergents given in the section "Safety regulations".

## 6.6. Filling the water/detergent tank

Before commencing the operation of filling the water/detergent tank, unscrew the cap (fig. 2, ref. 8) and open the tap (fig. 2, ref. 9) on the hose (fig. 2, ref. 10). This sequence of steps will allow air to escape from the hose/tank and, during the course of the filling operation, enable inspection of the level of water/detergent in the tank directly from the exposed hose.

Fill the tank (fig. 2, ref. 7), by way of the opening provided at the front, with clean water and low-foam detergent mixed in a suitable concentration: leave at least 5 cm between the surface of the liquid and the opening of the tank. With the filling operation completed, close the tap (fig. 2, ref. 9) and retighten the cap (fig. 2, ref. 8).

## 6.7. Preparing the machine for work

### IMPORTANT

**Before starting work, wear overalls, ear protectors, non-slip waterproof shoes, mask to protect the respiratory tract, gloves and all other personal protection devices recommended by the supplier of the detergent used or necessitated by the work environment.**

Proceed as follows before starting work.

- check the battery charge (recharge if necessary);
- lower the head by means of the pedal (fig. 5, ref. 9);
- make sure the dirty water drum (fig. 2, ref. 2) is empty. If necessary, empty it;
- fill the water/detergent tank.
- mount the most suitable brushes, drive disks or rollers for the floor and work to be performed (see paragraph 3.4);
- make sure the squeegee (fig. 2, ref. 6) is firmly attached and connected to the suction hose (fig. 6, ref. 4). Make sure the back blade is not worn.
- 

### i INFORMATION

**If you are using the machine for the first time, we recommend trying it out on a large obstacle-free surface first to acquire the necessary familiarity. Always empty the dirty water tank before filling the detergent tank again.**

For effective cleaning and to extend the working life of the machine, follow a few simple rules:

- prepare the work area by removing all possible obstacles;
- begin working from the furthest point to avoid walking on the area you have just cleaned;
- choose the straightest possible working routes;
- divide large floors into parallel rectangular sections.

If necessary, finish off by passing a mop or rag rapidly over parts inaccessible to the scrubber drier.

## 6.8. Working

After setting up the machine, proceed as follows:

- lower the squeegee by means of the corresponding lever (fig. 5, ref. 8);
- press the brush button (fig. 5, ref. 3) (LED on), the suction motor starts up automatically;
- press the suction button (fig. 5, ref. 2) if you want to disable detergent suction;
- press the brush/drive lever (fig. 5, ref. 7);
- Models with mechanical drive: When the brush motor is enabled and the drive lever is pulled, the motor which turns the brush and moves the machine starts up. A special mechanical drive device uses the friction between the brush and floor to generate a

forward movement. When the mechanical drive lever is released, the brush motor shuts down and the machine stops.

If the machine pulls to one side, restore a straight course by using the direction regulation knob (fig. 5, ref. 10). If the machine pulls to the right, turn the knob clockwise and vice versa.

- Models with electric drive: to move forwards or backwards, see paragraph 6.3. periodically check that the detergent is reaching the brushes and refill when it runs out. When there is no longer sufficient water in the detergent tank, the level indicator lights up (fig. 5, ref. 5). Stop and fill the tank; when working, check cleaning quality and if necessary adjust the flow of detergent by pressing the button (fig. 5, ref. 18); the amount of liquid delivered is indicated by the LEDs (fig. 5, ref. 20).

## IMPORTANT

**Empty the dirty water tank each time you fill the detergent tank.  
Never leave the suction motor on and detergent tap open when parked.**

- when the dirty water drum is full, the level indicator comes on (fig. 5, ref. 4) and after a few seconds the suction motor shuts off. You must stop working and empty the tank.
- if the warning LED (fig. 5, ref. 1) starts flashing, it means that the batteries are almost flat. After a few seconds the brushes shut down to prevent excessive discharge of the batteries. Charge the batteries.

### **At the end of work:**

- release the brush/drive lever (fig. 5, ref. 7) located under the handgrip. This turns the brush/drive motor off and the machine stops;
- stop the brush by pressing the button (fig. 5, ref. 3);
- lift the lever (fig. 5, ref. 8) to raise the squeegee from the floor to prevent the continuous pressure from warping the blades;
- remove the brushes (or drive disks) to prevent them from warping permanently;
- empty and clean the dirty water tank.

### **6.9. Some useful tips to get the most from your scrubber drier**

In the event of particularly stubborn dirt on the floor, washing and drying can be performed in two separate operations.

#### **6.9.1. Prewashing with brushes or pads**

- adjust detergent flow;
- press the brush button (fig. 5, ref. 3)
- lower the head;
- operate the drive lever to rotate the brushes;
- make sure the suction motor is off and the squeegee is raised;
- begin washing.

The flow of water must be adjusted in proportion to the desired advance speed. The slower the machine moves forwards, the less water is needed.

Persist when washing particularly dirty points to give the detergent time to perform its chemical action detaching and suspending the dirt and the brushes time to exert an effective mechanical action.

#### **6.9.2. Drying**

Lower the squeegee and with the suction motor on, pass over the same area washed previously. The result is equivalent to in-depth washing and subsequent ordinary maintenance will take less time.

To wash and dry at the same time, operate the brush, water, squeegee and suction motor simultaneously.

## 6.10. Draining the dirty water

### ! DANGER

**Use suitable personal protection devices.**

**Drain the water with the machine disconnected from the power supply.**

The dirty water drum drain hose is at the back left side of the machine.

To empty the tank:

- move the machine near a drain;
- detach the drain hose (fig. 7, ref. 2) from its seat by holding it near the fixing spring (fig. 7, ref. 3) and pulling horizontally;
- keeping the hose end as high as possible, unscrew and remove the cap (fig. 7, ref. 4);
- lower the end of the hose gradually, controlling the intensity of the flow of water by adjusting the height from the ground;
- check the amount of dirt left in the dirty water drum and if necessary wash it out. To facilitate cleaning and complete emptying of the drum, you are recommended to unfasten and lift it;
- when the dirty water has been totally drained, lower the dirty water drum (if previously lifted) and refasten to the detergent tank;
- close the drain hose (fig. 7, ref. 2) by replacing the cap (fig. 7, ref. 4), check that it is tightly closed and replace the hose in its housing.

### 👉 IMPORTANT

**When washing the dirty water drum, never remove the suction filter (fig. 9, ref. 2) from its housing and never direct the jet of water against the filter itself.**

You are then ready to wash and dry again.

## 6.11. Draining the clean water

### ! DANGER

**Use suitable personal protection devices.**

To empty the detergent solution tank:

- position the machine near a drain;
- detach the hose (fig. 8, ref. 1) from its holder and unscrew the cap (fig. 8, ref. 2).
- lower the hose, and open the tap (fig. 8, ref. 3) to empty the tank.

### i INFORMATION

**The water and detergent solution can also be used to wash the dirty water tank.**

## 7. PERIODS OF INACTIVITY

If the machine is not used for some time, remove the squeegee and brushes (or drive disks), wash them and put them away in a dry place (preferably in a bag or wrapped in plastic film) away from dust. Park the machine with the head lowered.

Make sure the tanks are completely empty and perfectly clean.

Disconnect the machine from the power supply.

Completely recharge the batteries and deposit them in the battery store. During long periods of inactivity, you should charge the batteries regularly (at least once every two months) to keep them constantly at maximum charge.

### 👉 IMPORTANT

**If you do not charge the batteries regularly, they may be irreparably damaged.**

## 8. BATTERY MAINTENANCE AND CHARGING

### ! DANGER

**Do not check the batteries by sparking.  
The batteries give off flammable fumes. Put out all fires and hot embers before  
checking or topping up the battery level.**

**Perform the operations described below in a ventilated area.**

To avoid permanent damage to the batteries, do not run them down completely. Remember that when the corresponding red LED (fig. 5, ref. 1) flashes on the control panel, you must charge the batteries.

#### 8.1. Charging procedure

- connect the battery charger connector to the battery wiring connector (fig. 4, ref. 1);

### 👉 IMPORTANT

**Depending on battery type you choose to install, make sure to program the  
supplied battery charger to the proper battery setting.**

- Charge the batteries as described in the battery charger manual;
- at the end of charging, disconnect the connectors;
- reconnect the battery wiring connector to the machine connector.

#### 8.2. On Board Charger Setting Instructions

### INFORMATION

**When machines are shipped with batteries installed, the charger and machine  
battery settings are factory-set. The machine is ready for operation.**

### 👉 IMPORTANT

**IMPORTANT:** For machines shipped without batteries, the machine and battery charger are factory set for Sealed Gel/AGM batteries as the default. If a different type of battery is going to be installed, the charger setting **MUST** be changed as described below. Failure to follow these instructions could result in damage to the battery. Depending on the type of battery selected (wet lead-acid or AGM/Gel), the machine battery setting **MUST** be changed accordingly. For information on how to make the battery selection, see the hang tag on the machine or refer to section 5.5 *Power supply batteries (battery models)*.

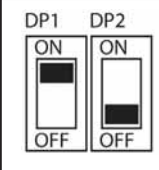
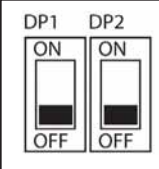
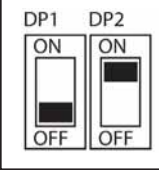
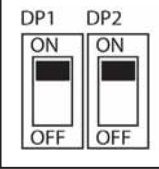
Setting	Battery Description
	IU1a-ACD, Generic Acid
	<b>IU1a-GEL, GEL “Exide Sonnenschien” (DEFAULT)</b>
	IU0U-GEL, GEL/AGM Generic
	IU1a-AGM, “Discover” AGM

DIP- SWITCH LOCATION LIFT UP THE CAP



## 9. MAINTENANCE INSTRUCTIONS

### ! DANGER

**Never perform any maintenance operations without first disconnecting the batteries.**

**Maintenance of the electrical circuit and all other operations not expressly required by this manual must be performed by specialised personnel only, in compliance with current safety legislation and as described in the maintenance manual.**

#### 9.1. Maintenance - General rules

Performing regular maintenance according to the Manufacturer's instructions improves performance and extends the working life of the machine.

When cleaning the machine, observe the following precautions.

- avoid the use of high pressure washers. Water could penetrate the electrical compartment or motors leading to damage or the risk of short circuit;
- do not use steam to avoid the heat warping plastic parts;
- do not use hydrocarbons or solvents as they could damage the cowling and rubber parts.

#### 9.2. Routine maintenance

##### 9.2.1 Suction motor air filter and float switch: cleaning

- Unscrew and remove the tank cap (fig. 9, ref. 1) from the dirty water drum (fig. 9, ref. 4);
- make sure the dirty water drum (fig. 9, ref. 4) is empty;
- clean the float switch (fig. 9, ref. 5) at the back of the dirty water drum, taking care not to direct the water jet directly against the float switch;
- remove the suction motor air filter (fig. 9, ref. 2) from the float switch support (fig. 9 ref. 3) inside the dirty water drum at the top;
- clean the filter with running water or the detergent solution used on the machine;
- dry the filter thoroughly before replacing it in the support. Make sure the filter is correctly located in its housing;
- screw the cap back on the dirty water drum.

##### 9.2.2 Basket filter: cleaning

- Remove the basket filter from the water fill hole at the front of the machine;
- clean the filter with running water or the detergent solution used on the machine;
- replace the filter back in its housing, making sure it is correctly positioned.

##### 9.2.3 Detergent filter: cleaning

- unscrew the cover located below the bottom tank (fig. 10, ref. 1);
- remove the detergent filter (fig. 10, ref. 2);
- clean the filter with running water or the detergent solution used on the machine;
- replace the filter in its housing, making sure it is correctly positioned and retighten the screw.

##### 9.2.4 Squeegee blades: replacing

The squeegee blades collect the film of water and detergent from the floor and prepare the way for perfect drying. With time, the constant rubbing makes the edge of the blade in contact with the floor rounded and cracked, reducing the drying efficiency and requiring it to be replaced.

##### Turning or replacing the blades:

- lower the squeegee by means of the corresponding lever (fig. 5, ref. 8);

- remove the squeegee (fig. 2 ref. 6) from its mount (fig. 6 ref. 2) by completely unscrewing the two knobs (fig. 6 ref. 3)
- remove the suction hose sleeve (fig. 6, ref. 4) from the squeegee;
- Open the catch (fig. 11, ref. 1).
- Remove the two blade retainers (fig. 11, ref. 2) by pushing them outwards then extracting them.
- Remove the blade.
- Reuse the same blade by reversing the edge in contact with the floor until all four edges are worn out, or replace with a new blade, fitting it onto the screws on the body of the squeegee.
- Reposition the two blade pressing devices by centering the wider part of the slots on the squeegee body fastening pins, then push the blade pressing devices inwards.

## INFORMATION

**Position the two blade pressing devices, ensuring that the arrows printed on the blade pressing devices are facing upwards as shown in figure (fig.11 A).**

- Close the hook again.
- Replace the squeegee on its support, following the instructions described previously.

### **9.2.5 Fuses: replacement (battery models)**

The fuses protecting the brush and suction motors are located in the fuse holder (fig. 12, ref. 1) attached to the dirty water drum above the machine battery compartment.

To replace the fuses:

- make sure the dirty water drum is empty and empty if necessary;
- raise the dirty water drum;
- raise the fuse holder cover and remove the fuse by unscrewing the fixing screws;
- fit a new fuse and close the fuse holder cover.
- lower the dirty water drum.

Fuse table: For the complete fuse table, see the spare parts catalogue.

## IMPORTANT

**Never use a fuse with a higher amperage than specified.**

If a fuse continues to blow, the fault in the wiring, boards (if present) or motors must be identified and repaired. Have the machine checked by qualified personnel.

### **9.3. Routine maintenance**

#### **9.3.1. Daily operations**

After each day's work, proceed as follows:

- disconnect the machine from the power supply;
- empty the dirty water tank and clean if necessary;
- clean the squeegee blades and check for wear. If necessary, replace.
- check that the suction hole in the squeegee is not blocked. If necessary remove encrusted dirt;
- recharge the batteries according to the procedure described.

#### **9.3.2. Weekly operations**

- Clean the dirty water drum float switch and make sure it is working correctly;
- clean the suction air filter and make sure it is undamaged. If necessary, replace.
- clean the detergent filter at the front opening of the detergent tank (fig. 2, ref. 7) and check that it is not damaged (replace if necessary);
- clean the suction hose;

- clean the dirty water tank and detergent tank;
- check the level of battery electrolyte and top up with distilled water if necessary.

### 9.3.3. Six monthly operations

Have the electrical circuit checked by qualified personnel.

## 9.4. Maintenance

The table below indicates the Person Responsible for each procedure.

O = Operator

T = Trained Personnel.

Interval	Person Resp.	Key	Description	Procedure	Lubricant/Fluid
Daily	O	1	Pad(s)	Check, flip or replace	
	O	1	Brush(es)	Check, clean	
	O	6	Squeegee	Clean, check for damage and wear	
	O	8	Scrub head skirt	Check for damage and wear	
	O	2	Recovery tank	Drain, rinse, clean float shut-off screen and debris tray	
	O	3	Solution tank	Drain, rinse	
	O	4	Severe Environment tank (option)	Check, refill	CAD
	O	5	Automatic battery watering tank (option)	Check, refill	DW
	O	7	Batteries	Charge if necessary	
Weekly	O	7	Battery cells	Check electrolyte level	DW
	O	7	Battery compartment	Check for liquid	
	O	6	Squeegee assembly drip trap reservoir (dual disk model)	Check. Clean	
50 Hours	O	2	Recovery tank lid seal	Check for wear	
	O	9	Solution tank filter	Remove and clean	
100 Hours	O	7	Battery watering system (option)	Check hoses for damage and wear	
200 Hours	O	7	Batteries, terminals and cables	Check and clean	
	T	13	Steering chain	Lubricate, check tension, and check for damage and wear	GL
	T	14	Steering cable	Check tension, Check for damage and wear	
750 Hours	T	10	Vacuum motor	Replace carbon brushes	
1250 Hours	T	11	Propel motor	Replace carbon brushes	
	T	12	Brush motor(s)	Replace carbon brushes	

### LUBRICANT/FLUID

DW Distilled water

CAD Commercial approved detergent

GL SAE 90 weight gear lubricant

# 10. TROUBLESHOOTING

## 10.1. How to resolve possible problems

[B]= battery machines

[C]= cable machines

[BT]= battery machines with electric drive

Possible problems affecting the whole machine.

PROBLEM	CAUSE	REMEDY
<b>The machine does not work</b>	• [B]= battery connector disconnected	• [B]= connect the batteries to the machine
	• [B]= the batteries are flat	• [B]= recharge the batteries
<b>The brushes do not turn</b>	• [B], [BT]= you have not used the brush switch	• press the brush switch
	• you have not pressed the brush lever	• press the brush lever
	• [B]= the motor thermal cutout has tripped; the motor is overheated	• [B]= release the brush lever; leave the machine to cool down for at least 45'
	• [B], [BT]= the power supply or motor thermal cutout connectors are disconnected	• [B], [BT]= reconnect the power supply or motor thermal cutout connectors
	• [B] [BT]= the brush motor fuse has blown	• [B] [BT]= have someone check and eliminate the causes responsible for the blown fuse, then replace
	• [B] [BT]= the batteries are flat	• [B] [BT]= recharge the batteries
	• the reduction unit is faulty	• have the reduction unit replaced
<b>The machine does not clean evenly</b>	• the brush or disks are worn	• replace
	• the motor is faulty	• have the motor replaced

<b>No detergent is delivered</b>	• the detergent tank is empty	• fill it
	• the hose delivering the detergent to the brush is blocked	• unblock and open the circuit
	• the solenoid valve is dirty or faulty	• clean or replace the solenoid valve
<b>Detergent flow does not stop</b>	• the solenoid valve is dirty or faulty	• clean or replace the solenoid valve
<b>The suction motor does not start</b>	• there is no power to the suction motor or the motor is faulty	• check that the motor power connector is correctly connected to the main wiring; if it is correctly connected, have the motor replaced
	• <b>[B] [BT]=</b> the fuse has blown	• <b>[B] [BT]=</b> replace the fuse
<b>The squeegee does not clean or suction is ineffective</b>	• the edge of the rubber blades in contact with the floor is worn	• replace the rubber blade
	• the squeegee or hose is blocked or damaged	• unblock and repair the damage
	• the float switch has tripped (dirty water drum), is clogged by dirt or broken	• empty the dirty water drum or reset the float switch
	• the suction hose is blocked	• unblock the hose
	• the suction hose is not connected to the squeegee or is damaged	• connect or repair the hose
	• there is no power to the suction motor or the motor is faulty	• check that the motor power connector is correctly connected to the main wiring and that the fuse is not blown; in the second case have the motor replaced
	• The blade pressing devices may have been attached upside down	• Check for proper orientation
<b>The machine does not move</b>	• there is no power to the brush/drive motor or it is faulty	• in the first case, press the brush button and push down the brush/drive lever; in the second case, check that the brush motor is correctly connected to the main wiring; in the third case, have the motor replaced.
	• the reduction unit is broken (therefore the brush does not turn)	• have the reduction unit replaced
	• the brush motor thermal cutout has tripped; the motor has overheated	• stop the machine, turn it off and leave it to cool for at least 45'
	• <b>[B] [BT]=</b> the batteries are flat and the brushes have shut down	• <b>[B] [BT]=</b> recharge the batteries

<p><b>The machine tends to pull to one side</b></p>	<ul style="list-style-type: none"> <li>• the direction adjustment knob must be adjusted appropriately for the floor</li> </ul>	<ul style="list-style-type: none"> <li>• regulate the direction of movement by adjusting the direction adjustment knob</li> </ul>
<p><b>The batteries do not provide the normal working time</b></p>	<ul style="list-style-type: none"> <li>• the battery poles and charging terminals are dirty and oxidised</li> <li>• the electrolyte level is low</li> <li>• the battery charger does not work or is unsuitable</li> <li>• there are considerable differences in density between the various elements of the battery</li> <li>• you are using the machine with excessive pressure on the brushes</li> <li>• there are considerable differences in density between the various elements of the battery</li> </ul>	<ul style="list-style-type: none"> <li>• clean and grease the poles and terminals, recharge the batteries</li> <li>• top up all the elements with distilled water as described in the instructions</li> <li>• see battery charger instructions</li> <li>• replace the damaged battery</li> <li>• reduce pressure on the brush</li> <li>• replace the damaged battery</li> </ul>
<p><b>The battery discharges too fast during use, even though it has been charged correctly and when tested with a hydrometer at the end of recharging, it turned out to be uniformly charged</b></p>	<ul style="list-style-type: none"> <li>• the battery is new and does not deliver 100% of its expected capacity</li> <li>• the machine is being used at maximum capacity for continuous periods and the working time is not sufficient</li> <li>• the electrolyte has evaporated and does not cover the plates completely</li> </ul>	<ul style="list-style-type: none"> <li>• the battery must be "run-in" by performing 20-30 charges and discharges to obtain maximum performance</li> <li>• if possible, use batteries with a higher capacity or replace the batteries with others charged previously</li> <li>• top up all elements with distilled water until the plates are covered then recharge the battery</li> </ul>
<p><b>The battery discharges too fast during use, recharging with an electronic battery charger is too fast and after recharging the battery supplies the right voltage (about 2.14V for each element without load), but when tested with a hydrometer is found not to be uniformly charged</b></p>	<ul style="list-style-type: none"> <li>• the battery supplied filled with acid by the Manufacturer has been stored for too long before being recharged and used for the first time</li> </ul>	<ul style="list-style-type: none"> <li>• if recharging with a normal battery charger is not effective, you must use a double recharging cycle: <ul style="list-style-type: none"> <li>- charge slowly over a 10 hour period at a current of 1/10 the nominal capacity for 5 hours (e.g. for a 100Ah(5) battery the current must be set at 10A, using a manual battery charger);</li> <li>- rest for one hour;</li> <li>- charge with the normal battery charger.</li> </ul> </li> </ul>
<p><b>At the end of charging with the electronic battery charger, the battery does not provide the correct voltage (about 2.14 V per element without load) and appears to be uniformly not charged when tested with a hydrometer</b></p>	<ul style="list-style-type: none"> <li>• the battery has not been connected to the battery charger (for example, because the low voltage connector of the battery charger has been erroneously connected to the machine connector)</li> </ul>	<ul style="list-style-type: none"> <li>• connect the battery charger to the battery connector</li> </ul>

	<ul style="list-style-type: none"> <li>the battery charger and power socket to which the battery is connected are not compatible</li> </ul>	<ul style="list-style-type: none"> <li>check that the power supply characteristics indicated on the battery charger rating plate comply with those of the mains power supply</li> </ul>
	<ul style="list-style-type: none"> <li>the battery charger has not been installed correctly</li> </ul>	<ul style="list-style-type: none"> <li>taking the actual voltage available at the socket into account, make sure that the connections of the primary of the transformer inside the battery charger are correct (consult the battery charger manual)</li> </ul>
	<ul style="list-style-type: none"> <li>the battery charger is not working</li> </ul>	<ul style="list-style-type: none"> <li>make sure there is voltage to the battery charger, that the fuses are not blown and that the current reaches the battery; try charging with another rectifier. If the battery charger is not working, contact the technical service centre and indicate the serial number of the battery charger</li> </ul>

<p><b>At the end of charging with the electronic battery charger, the battery does not provide the correct voltage (about 2.14 V per element without load) and only one or a few elements are found to be discharged when tested with a hydrometer</b></p>	<ul style="list-style-type: none"> <li>one or more elements are damaged</li> </ul>	<ul style="list-style-type: none"> <li>replace the damaged elements if possible. For 6 or 12 V single block batteries, replace the entire battery</li> </ul>
--	--	--

<p><b>The electrolyte in the battery is turbid</b></p>	<ul style="list-style-type: none"> <li>The battery has reached the end of the charging/discharging cycles declared by the manufacturer</li> </ul>	<ul style="list-style-type: none"> <li>replace the battery</li> </ul>
	<ul style="list-style-type: none"> <li>the battery has been recharged with too high a current</li> </ul>	<ul style="list-style-type: none"> <li>replace the battery</li> </ul>
	<ul style="list-style-type: none"> <li>the battery has been charged beyond the limit suggested by the Manufacturer</li> </ul>	<ul style="list-style-type: none"> <li>replace the battery</li> </ul>

<p><b>The water/detergent drain hose does not show the level of the solution in the tank during the filling operation.</b></p>	<ul style="list-style-type: none"> <li>Tap on water/detergent drain hose closed</li> </ul>	<ul style="list-style-type: none"> <li>Remove the cap and open the tap</li> </ul>
	<ul style="list-style-type: none"> <li>Cap on water/detergent drain hose not unscrewed</li> </ul>	<ul style="list-style-type: none"> <li>Remove the cap and open the tap</li> </ul>

## 11. DISPLAY ALARMS

### **ACC / MAN [Acc / NAn]: ACCelerator / MAN**

The traction lever has been pulled while machine switching ON by the key. Release the traction lever to enable the traction.

### **POT : POTentiometer**

The traction potentiometer on PCB is broken or badly connected with the circuit board.

Release and push the traction lever: If the error is still on the display, check the potentiometer or replace the circuit board.

### **Lim [Lin]: Limitation**

The traction MOSFET reached the max current limitation . The traction is blocked, It can appears if machine climbs long ramp and traction board overload . Switch off and wait 15 minutes to cool down the card. If problem persists check the current consumption of the traction motor and check if any mechanical blockage on it .

### **Hom [Hon] : MOSFET thermal sensor**

It appears when the thermal sensor inside the traction MOSFET is being activated. Wait 15 min until the card cool down and try again.

If it not disappear is necessary to replace the circuit board.

### **Hot : Overheating**

Traction motor internal temperature sensor is engaged. Wait 30 minutes till the temperature decrease and try again , or check the wiring between motor and card . If unsolved replace the sensor, it is located beside the carbon brushes.

### **MoS [noS]: MOSFET**

- The coil of the main contactor is open or in short circuit and the brush or traction function are activated,
- The traction MOSFET is broken or in short circuit : the traction is blocked.
- The vacuum motor's relay has the coil in short circuit , replace it .
- Check the coil of the black traction motor relay positioned underneath the chassis.
- If the problem is still unsolved replace the traction card or the main contactor..

### **MoF [NoF]: Mosfet**

The traction MOSFET is broken internally ; the traction is blocked , brush and vacuum still works.

Replace the traction board.

### **bLt : drive blocked**

The battery voltage is too low: the traction and all other functions are blocked . Charge the batteries, replace them if necessary.

### **AcS : Brush command problem**

The brush motor's contactor is not engaged properly:

Push the brush switch and if the error is still on the display, check the connection between panel board and brush contactor. If the connections are ok, replace the contactor located on PCB underneath the recovery tank.

### **AcA : Vacuum motor command problem**

The vacuum relay is not properly activated by the panel board,

Push the vacuum function switch and if the error is still on the display, check the relay connections. If the connections are ok, replace the vacuum motor relay located on PCB underneath the recovery tank.

### **ACH : Solution solenoid valve problem**

It appear is the fuse of solenoid valve is blown , or if the coil of the valve is interrupted internally or the wiring between PCB and solenoid valve is interrupted . Check and replace parts if necessary.

### **FuP : Fuse**

- The coil of the main contactor does not close properly and the other functions are activated.

- Internal problem on the display card , or incorrect contact between display card and Battery negative cable.

### CLH : Clock

Internal problem in the display card main memory . Replace the display board

### err : Error

It appears when there is a general malfunctioning error in the electronic board . Replace the display board .

## 12. T290 - RECOMMENDED SPARE PARTS

Part Number	Description
9017703	BRUSH ASSY, DISK, SCB, 50CM, PYP
9017704	BRUSH ASSY, DISK, SCB, 50CM, PYP, SOFT
9017710	DRIVER ASSY, PAD, 50CM [STANDARD]
9017695	BLADE, SQGE, FRONT, 880L, LATEX [OPTION]
9017694	BLADE, SQGE, REAR, 900L, LATEX [OPTION]
9017696	BLADE, SQGE, FRONT, 880L, PYU [OPTION]
9017698	BLADE, SQGE, REAR, 900L, PYU [OPTION]
9017699	BLADE, SQGE, FRONT, 880L, LINATEX [STANDARD]
9017702	BLADE, SQGE, REAR, 900L, LINATEX [STANDARD]
9017713	FILTER, VACUUM
9017711	SEAL, COVER, RECVY TANK
9017712	HOSE ASSY, RECOVERY
9017686	BRUSH KIT, CARBON, BRUSH MOTOR [4 PC]
9017687	BRUSH, CARBON, VAC FAN MOTOR
9018034	BRUSH, CARBON, TRANSAXLE MOTOR
9017715	CABLE, LIFT, SQGE
TBFX01299	HOSE ASSY, DRAIN
9017718	VALVE, WATER, SOLENOID, 24VDC
9017788	CASTER, SWIVEL
CUVR00294	BEARING, SUPPORT [PROPEL MODEL]
CUVR00293	BEARING , FLANGE [PROPEL MODEL]
9017719	BEARING, AXLE
9018584	FILTER, WATER, SOLNT, COMPL
9017725	MOTOR, BRUSH, 24VDC
9017716	FAN, VACUUM
897285	MOTOR, TRACTION, 24V 145W
L-GF12105V	BATTERY, 12V , GEL 105AH
PMVR06660	SQUEEGEE ASSY, LINATEX BLADES [T290]
9017726	CIRCUITBOARD, MAIN
897289	CIRCUITBOARD, DISPLAY [PROPEL MODEL]
897186	CIRCUITBOARD, DISPLAY [PAD ASST MODEL]
MEVR01428	FUSE 2A, MAIN CIRCUIT BOARD
9018332	FUSE 50A, MAIN CIRCUIT BOARD
9018333	FUSE 40A, MAIN CIRCUIT BOARD
897301	FUSE 30A, MAIN CIRCUIT BOARD [PROPEL MODEL]
9017722	GUARD, SPLASH (OPTION)
9017737	FLOAT, SHUTOFF

## 13. T390 - RECOMMENDED SPARE PARTS

Part Number	Description
9017816	BRUSH ASSY, DISK, SCB, 35CM, 3-LUG, PYP
9017730	BRUSH ASSY, DISK, SCB, 35CM, 3-LUG, PYP, SOFT
9017820	DRIVER ASSY, PAD, 35CM, 3-LUG [STANDARD]
9017801	BLADE, SQGE, FRONT, 1020L, LATEX [OPTION]
9017804	BLADE, SQGE, REAR, 1020L, LATEX [OPTION]

9017806	BLADE, SQGE, FRONT, 1020L, PYU [OPTION]
9017811	BLADE, SQGE, REAR, 1020L, PYU [OPTION]
9017813	BLADE, SQGE, FRONT, 1020L, LINATEX [STANDARD]
9017814	BLADE, SQGE, REAR, 1020L, LINATEX [STANARD]
9017713	FILTER, VACUUM
9017711	SEAL, COVER, RECOVERY TANK
9017712	HOSE ASSY, RECOVERY
9017686	BRUSH KIT, CARBON, BRUSH MOTOR [4 PC]
9017687	BRUSH, CARBON, VAC FAN MOTOR
9018034	BRUSH, CARBON, TRANSAXLE MOTOR
9017715	CABLE, LIFT, SQGE
TBFX01299	HOSE ASSY, DRAIN
9017718	VALVE, WATER, SOLENOID, 24VDC
9017788	CASTER, SWIVEL
9017745	BEARING, WHEEL
9018584	FILTER, WATER, SOLUTION, COMPLETE
9017792	MOTOR, BRUSH, 24VDC
9017716	FAN, MOTOR
897349	MOTOR TRACTION 24V 200W 150G
9017726	CIRCUITBOARD, MAIN
L-GF12105V	BATTERY, 12V , GEL 105AH
PMVR06661	SQUEEGEE ASSY, LINATEX BLADES [T390]
897289	BOARD
MEVR01428	FUSE 2A
9018332	FUSE 50A
9018333	FUSE 40A
897301	FUSE 30A [PROPEL MODEL]
9017722	GUARD, SPLASH [OPTION]
9017737	FLOAT, SHUTOFF



**Tennant Company**

PO. Box

10400 Clean Street

Eden Prairie, MN 55344-2650

Phone: (800) 553- 8033

[www.tennantco.com](http://www.tennantco.com)

Copyright © 2021 Tennant Company. All rights reserved.